



Where
Every Workspace Need
Meets Its Solution

Welcome to our new catalogue for an update on our wide range of innovative products.

TWINCO Solution gives you swift, efficient and easy access to everything you need to know about us. Visit our website at www.twincosolution.com for quick and continuously updated access.

Our website provides:

- Lots of exciting news – continuously updated
- Downloads of dimension and assembly drawings
- Logistics and environmental data
- Downloads of product photos and ISO or TÜV certificates

TWINCO Solution develops office, warehouse and computer accessories for the discerning professional user.

Best regards
TWINCO Solution

Sehr geehrte Kundin, sehr geehrter Kunde, Mit unserem neuen Katalog präsentieren wir erneut unsere breite Auswahl an innovativen Produkten.

In unserem Katalog finden Sie:

- Eine klare und schnelle Übersicht über unser Warenangebot
- Viele interessante Neuigkeiten
- Die bereits bekannten internationalen Produkte
- Allgemeine Informationen zu TWINCO Solution

Auf unserer Webseite finden Sie:

- Viele interessante Neuigkeiten regelmäßig aktualisiert
- Download von Maß- und Montagezeichnungen
- Logistik- und Umweltinformationen
- Download von Produktfotos und TÜV-Zertifikaten

TWINCO Solution entwickelt Computerzubehör, Lagezubehör und Bürozubehör für professionelle Anwender, für die Qualität unabdingbar ist.

Mit freundlichen Grüßen
TWINCO Solution



3-15

Stepstools / Rollhocker
Plastic Step ladders / Klapptritte
Metal Step ladders / Klapptritte
Wobble stool / Wobble-Hocker
Anti-fatigue stools / Stehhilfen



16-25

Footrests / Fußstützen



26-34

A Boards / Kundenstopper
Snapframes / Plakatrahmen
Mobile Whiteboard
Flip Chart / Flipchart
Whiteboard / Cork Board / Felt Board
Glass Whiteboard / Glas Whiteboard



35-40

Literature Holders / Bodenständeren



41-46

Waste Bins / Papierkorb
Umbrella stand / Schirmständer
Acrylic Displays / Acryl Prospekthalter
Belt Barrier / Absperrband



47-53

Plastic Cabinet / Multischrank
Copyholder / Konzepthalter
Cable Pipes / Kabelkanäle



54-59

CPU Holders / CPU Halter
Letter Tray System / Briefablagensystem
Pen Tray - rotatable / Stiftschale - drehbar
Keyboard Drawer / Tastaturauszug
Sack Truck - Foldable Sackkarre - Klappbar
Whiteboard accessories / Magnetische Produkte



60-62

Sack Truck / Foldable Sackkarre - Klappbar
Coat Stand / Coat Hanger



63-68

CLICK Workstations / Terminaltische
Mobile Computer Stand / Multi-functional Desk
Portable table / Tragbarer Tisch

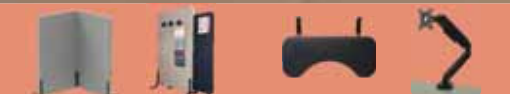

69-75

Acoustic Partition / Akustische Trennwand
Forearm Support / Unterarmstütze
Monitor Arm Mount Stand / Monitorhalterung



Stepstools/Letter Tray Systems
Rollhocker/ Briefablagensysteme
Footrest/ Fußstütze

6000 TWIN LIFT Stepstool

Plastic Stepstool



★ EN 14183 ★
★ AS 1892.1 ★
★ ANSI-ASC A14.11 ★

Colours:

6000-1 Black Ral 9005	6000-4 Red Ral 3020	6000-5 Blue Ral 5005	6000-9 Light Grey Ral 7035	6000-7 Basalt Grey Ral 7012	6000-2 White Ral 9016
------------------------------------	----------------------------------	-----------------------------------	---	--	------------------------------------

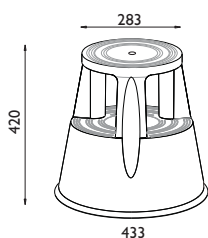

- Tolerates heavy use without losing its looks:
 - dent-proof;
 - scratch-proof;
 - rust-proof;
- Insert molding TPE rubber ring. Rubber bonded very well with the plastic stool;
- Mobile on 3 spring loaded castors that retract when weight is applied;
- Stable and durable stool;
- Max. Load: 150Kg; TUV/GS certified.
- Also comply with American standard (Extra Heavy Duty rating) and Australian standard (Industrial duty rating)



6100 TWIN SUPERSTEP Stepstool

Plastic Stepstool - Upgrading version from 6000



★ EN 14183 ★
★ AS 1892.1 ★
★ ANSI-ASC A14.11 ★

Colours:

6100-1 Black Ral 9005	6100-4 Red Ral 3020	6100-5 Blue Ral 5005	6100-9 Light Grey Ral 7035	6100-7 Basalt Grey Ral 7012	6100-2 White Ral 9016	6100-3 Yellow Ral 1003	6100-10 Green Ral 5018
------------------------------------	----------------------------------	-----------------------------------	---	--	------------------------------------	-------------------------------------	-------------------------------------

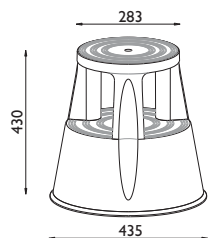

- 10mm higher than the old version;
- More stable and durable stool –better product in high quality;
- All round edges and corners, more user friendly;
- Tolerates heavy use without losing its looks:
 - dent-proof;
 - scratch-proof;
 - rust-proof;
- Insert molding TPE rubber ring. Rubber bonded very well with the plastic stool;
- Mobile on 3 spring loaded castors that retract when weight is applied;
- Max. Load: 150Kg; TUV/GS certified.
- Also comply with American standard (Extra Heavy Duty rating) and Australian standard (Industrial duty rating)



6200 TWIN EASY STEP® Stepstool
Plastic Stepstool



- * EN 14183 *
- * AS 1892.1 *
- * ANSI-ASC A14.11*

Colours:

- 6200-1**
Black
Ral 9005
- 6200-4**
Red
Ral 3020
- 6200-5**
Blue
Ral 5005
- 6200-9**
Light Grey
Ral 7035

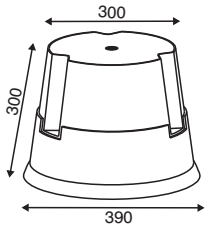

- Strong and stable
 - dent-proof;
 - scratch-proof;
 - rust-proof;
- Mobile on 3 spring loaded castors that retract when weight is applied;
- Max. Load: 150Kg; TUV/GS certified.

6300 TWIN STEEL Stepstool
Metal Stepstool



- * EN 14183 *
- * AS 1892.1 *
- * ANSI-ASC A14.11*

Colours:

- 6300-1**
Black
Ral 9005
- 6300-4**
Red
Ral 3020
- 6300-5**
Blue
Ral 5005
- 6300-9**
Light Grey
Ral 7035
- 6300-7**
Basalt Grey
Ral 7035
- 6300-2**
White
Ral 9016
- 6300-3**
Yellow
Ral 1003
- 6300-10**
Green
Ral 5018

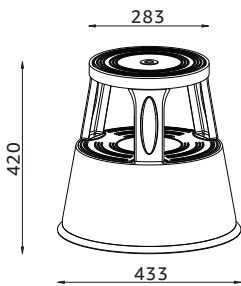

- Tolerates heavy use without losing its looks:
 - dent-proof;
 - scratch-proof;
 - rust-proof;
- Mobile on 3 spring loaded castors that retract when weight is applied;
- Strong powder coated steel construction;
- Steps feature non-slip rubber mats;
- Rubber ring foot, durable and stable;
- Max. Load capacity: 150Kg; TUV/GS certified.



Heavy Duty Safety Steps

Colours:



6600 TWIN Heavy Duty Safety Steps, 1-Step

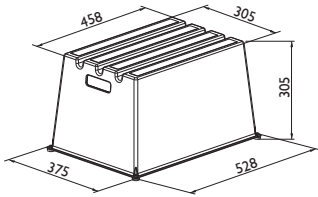

- Material: UV stabilized HDPE;
- With anti-slip strips and feet;
- Resistance to most chemicals;
- Max. Load: 230Kg;
- TUV/GS certified;
- Also comply with American standard (Extra Heavy Duty rating) and Australian standard (Industrial duty rating)



- EN 14183 •
- AS 1892.1 •
- ANSI-ASC A14.11 •



Colours:



6700 TWIN Heavy Duty Safety Steps, 2-Step

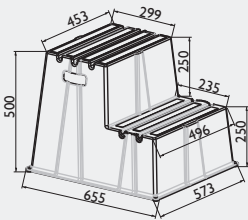

- Material: UV stabilized HDPE;
- With anti-slip strips and feet;
- Resistance to most chemicals;
- Max. Load: 230Kg;
- TUV/GS certified;
- Also comply with American standard (Extra Heavy Duty rating) and Australian standard (Industrial duty rating)



- EN 14183 •
- AS 1892.1 •
- ANSI-ASC A14.11 •

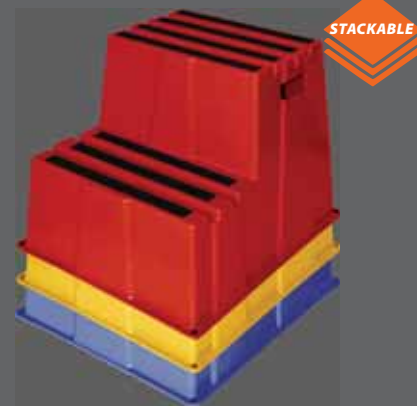

Colours:



6800 TWIN Heavy Duty Safety Steps, 3-Step

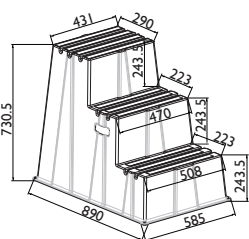

- Material: UV stabilized HDPE;
- With anti-slip strips and feet;
- Resistance to most chemicals;
- Max. Load: 230Kg;
- TUV/GS certified;
- Also comply with American standard (Extra Heavy Duty rating) and Australian standard (Industrial duty rating)



- EN 14183 •
- AS 1892.1 •
- ANSI-ASC A14.11 •



Heavy Duty Safety Steps

Colours:



6900 TWIN Heavy Duty Safety Steps - 4 Step



- * EN 14183 *
- * AS 1892.1 *
- * ANSI-ASC A14.11*

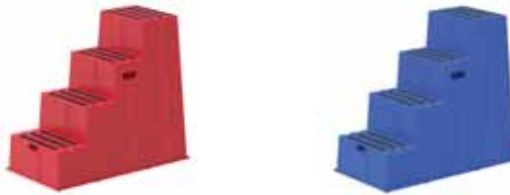
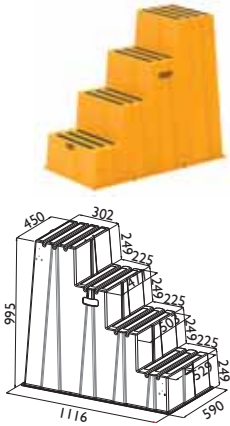

- Material: UV stabilized HDPE;
- Safe to use. With anti-slip strips and feet;
- Resistance to most chemicals;
- Sturdy and Reliable. Max. Load: 230Kg;
- TUV/GS certified;
- Also comply with American standard (Extra Heavy Duty rating) and Australian standard (Industrial Duty rating)



6910 TWIN Mobile Heavy Duty Safety Steps, 4-Step

Model 6900 with wheels



- * EN 14183 *
- * AS 1892.1 *
- * ANSI-ASC A14.11*



- High quality silencing wheels;
- Wheels Size: 100xB30 mm;
- Quiet & Smooth operation;
- Protect your floors;
- Easy to install;
- Convenient and Easy to Use.



6920 TWIN Mobile Heavy Duty Safety Steps with Handrails, 4-Step

Model 6900 with handrails and wheels



- * EN 14183 *
- * AS 1892.1 *
- * ANSI-ASC A14.11*

Optional cross bar

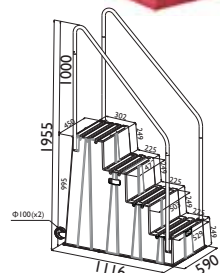

- Fall Prevention; Durable and easy grab metal handrails for extra safety and support;
- Convenient and Easy to Use: Mounted 2 high quality casters for portable use;
- Sturdy and Reliable. Chemical and UV resistant;
- Easy to be assembled. Handrails and wheels assembled with screws. screws kits included.
- Handrails and wheels are packed separately, convenient for pallet transportation.
- Comply with TUV/GS En 14183 / American standard (Extra Heavy Duty rating) / Australian standard (Industrial Duty rating).

Step ladder

6930 TWIN Heavy Duty Safety Steps

- ★ EN 14183 ★
- ★ AS 1892.1 ★
- ★ ANSI-ASC A14.11 ★



Colours:

- | | | |
|------------------------------|---------------------------|----------------------------|
| 6930-3
Yellow
Ral 1003 | 6930-4
Red
Ral 3000 | 6930-5
Blue
Ral 5002 |
|------------------------------|---------------------------|----------------------------|

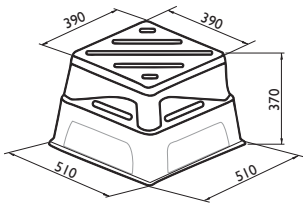

- Features 4-way access;
- With anti-slip strips and feet;
- Resistance to most chemicals;
- Comply with EN 14183 standard;
- TUV/GS certified;
- Max. Load capacity: 230Kg;
- Stackable for space saving during transportation.
- Also comply with American standard (Extra Heavy Duty rating) and Australian standard (Industrial Duty rating)



3028 TWIN Aluminum Step Ladder with Tools Tray

- Aluminum Step Ladder with tool tray;
- Galvanized steel for top step;
- Anti-slip rubber foot;
- Foldable for space saving;
- Comply with EN 131 standard; TUV/GS certified;
- Max. loading capacity 150Kg.



3028-3

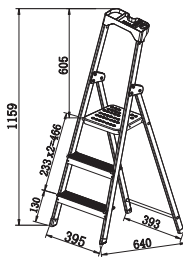

3028-4

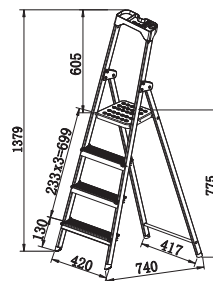

3028-5

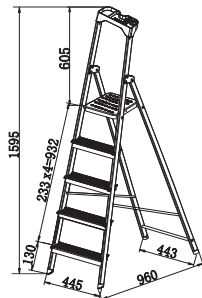

2034 TWIN Steel Portable Step Ladder

- Powder coated Steel Step Ladder;
- Anti-slip plastic mats and rubber foot;
- Portable with handle;
- Foldable for space saving;
- Comply with EN 131 standard;
- TUV/GS certified;
- Max. loading capacity 150Kg.

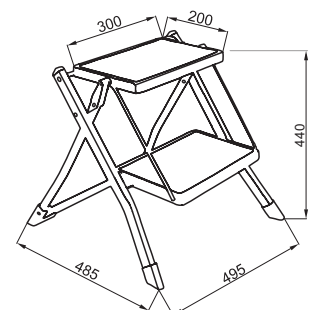

6400/6500-11 TWIN MINI 2-Step Ladder/2- Stufenleiter



6400-11



6400-11-2

Colour: Aluminium
Wheels: Mobile on 4 castors
Max. Load: 150 kg

- Stable aluminum construction
Mobile ladder with 2 steps and 4 steerable wheels . the ladder is collapsible , so that when not in use takes up minimal space .
6400-11 : double access.
6400-11-2 : single access.

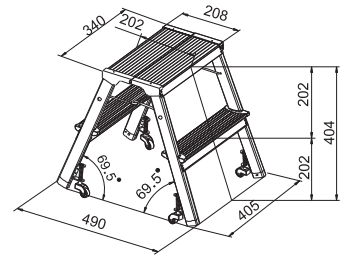

6500-11



6500-11-2

Colour: Aluminium
Wheels: Mobile on 4 castors
Max. Load: 150 kg

- Stable aluminum construction
Mobile ladder with 3 steps and 4 steerable wheels . the ladder is collapsible , so that when not in use takes up minimal space .
6500-11 : double access.
6500-11-2 : single access.

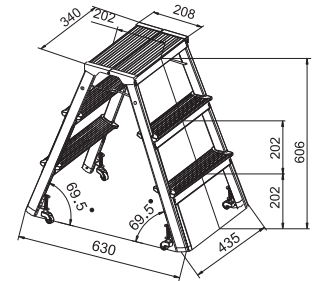

2029/2030/2031/2061A/2061B TWIN STEEL Stålstige/Steel ladder/Stahlleiter

Colour: White/black
Max. Load: 150 kg

2029/2030/2031 Steel ladder

Powder coated squared tubes and safety guard rail;
Anti-slip rubber feet;
Wide anti-slip steps (300x200mm).

2061A/2061B Steel ladder

Powder coated round tubes and safety guard rail;
Anti-slip rubber feet included;
Wide anti-slip steps (380x260mm);
With soft poly foam handle.



2029



2030



2031



2061A



2061 B

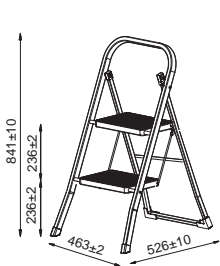

2029

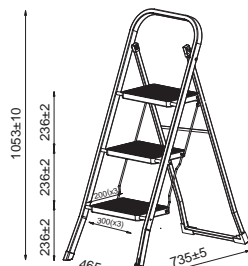

2030

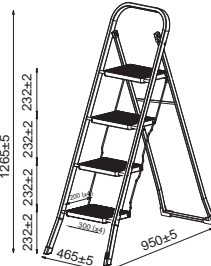

2031

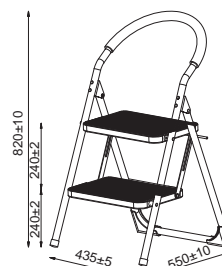

2061A

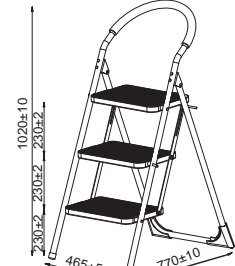

2061 B

Anti-fatigue Stool /Kunststofftritt, einstufig

6110 TWIN Anti-fatigue Stool /Anti-Fatigue-Hocker

- Seat made of robust, hardwearing PU foam;
- Power coated metal frame with 4 none-slip feet prevent sliding;
- Height adjustable from 630 to 885mm, 8 easy height settings;
- Seat can be swivelled by 30° sideways with automatic reset;
- Seat can be tilted by 20° with 4 easy angle settings.

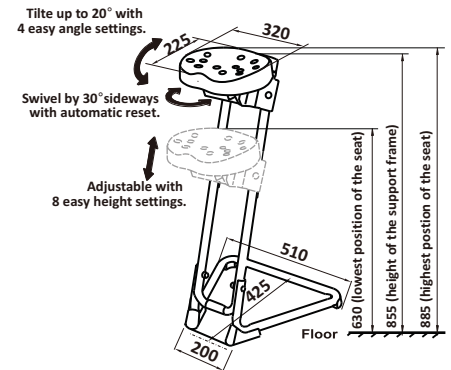

6116 TWIN Foldable Anti-fatigue Stool /Anti-Fatigue-Hocker



- Seat made of foam covered with leather;
- Power coated metal frame with 4 none-slip feet prevent sliding;
- Seat size: 370x220mm; Back support size: 320x230mm;
- Height adjustable for both seat and seat back support;
- Adjustable height range: 530-830mm.

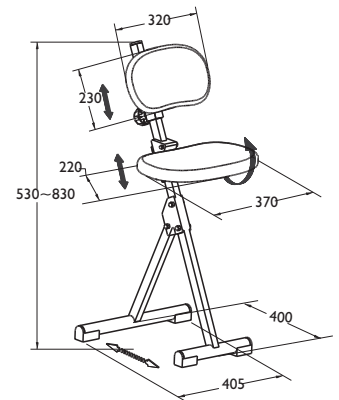

6121 TWIN Standing Stool

- **Promotes Neutral posture for Strong Back:** Standing desk chair for leaning, sitting, perch stool. Front tilting seat; reduces “tail-bone numbness”;
- **Ultra Stable Construction:** Doesn't Tip or Slide when in use;
- **Removable mat:** The anti-fatigue mat provides a comfy stable work-base.

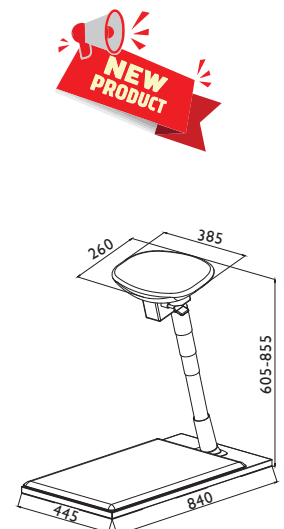

6113 / 6114 / 6117 / 6118 / 6119 / 6120 TWIN Gas Lift Anti-fatigue Stool /Anti-Fatigue-Hocker



6113



6114



6117



6118



6119



6120



- Seat made of robust, hardwearing PU foam;
- Gas Lift height adjustment;
- Power coated metal frame;
- 4 none-slip feet prevent sliding;
- Cover for gas lift to protect against dust and dirt.

6113: Seat size: length 340, depth 210mm;
Height Adjustable from 620 to 790mm.

6114: Seat size: length 330, depth 175mm;
Height Adjustable from 630 to 800mm.

6117: Seat size: length 315, depth 220mm;
Height Adjustable from 580 to 750mm.
Adjustable seat inclination from 11° to 23°.

6118: Seat size: length 350, depth 240mm;
Height Adjustable from 580 to 750mm.
Adjustable seat inclination from 4° to 16°.

6119: Seat size: length 330, depth 230mm;
Seat back support size: length 170, height 150mm;
Height Adjustable from 590 to 760mm.
Adjustable seat inclination from 7° to 19°.

6120: Seat size: length 390, depth 260mm;
Height Adjustable from 665 to 890mm.
Adjustable seat inclination from 0° to 10°.

Ergonomic Task Chair

15008/15009/15018 TWIN Ergonomic Task Chair



15008

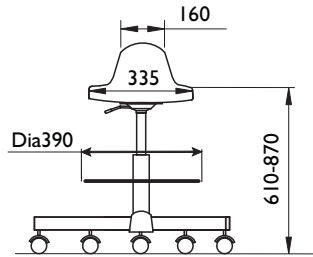

15018

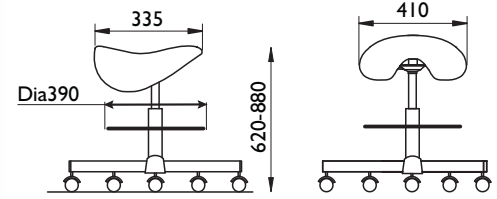

15009

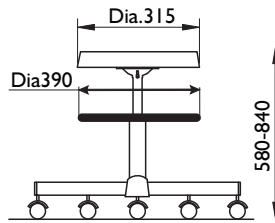

- Molded PU foam seat and back in black;
- BIFMA standard, Class 3 gas cylinder;
- Height adjustable stainless steel foot ring;
- Chromed steel base;
- 5 silence castors and gliders.

15003/15017/15019 TWIN Ergonomic Task Chair



15003

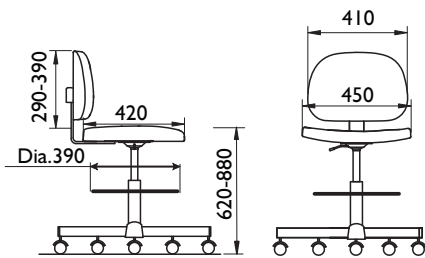

15019

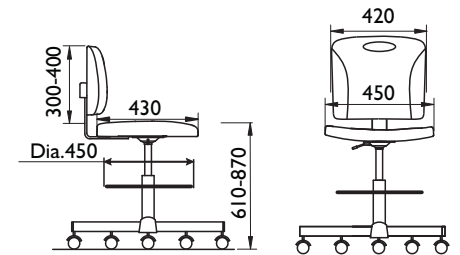

15017

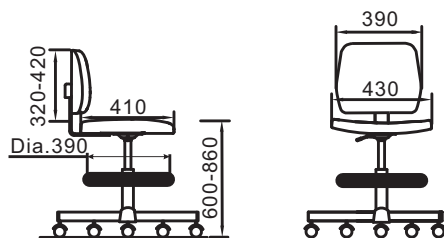

- Molded PU foam seat and back in black;
- BIFMA standard, Class 3 gas cylinder;
- Height and angle adjustable back support;
- Height adjustable stainless steel foot ring;
- Chromed steel base;
- 5 silence castors and gliders.

6131 TWIN Ergonomic Wobble Chair

Colours: 6131-1 Black 6131-5 Blue
6131-4 Red 6131-9 Grey



- High quality stool with excellent sitting comfort;
- Height-adjustable from 65 to 84.5 cm(Gas-lift mechanism);
- Ergonomically shaped and comfortable thick upholstered seat;
- 65 kg/m³ density molded polyurethane foam;
- Durable and abrasion-resistant polyester fabric cover (210g/m²);
- Fitted with non-slip rubber on the bottom;
- Swing firm base could bear 120kg weight;
- The user has complete freedom of movement while seated.

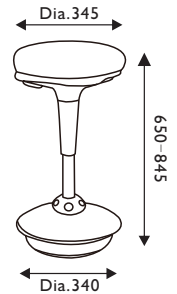

6156 TWIN Ergonomic Wobble Chair

Colours: 6156-1 Black 6156-5 Blue
6156-4 Red 6156-9 Grey



- High quality stool with excellent sitting comfort;
- Height-adjustable from 65.5 to 83.5 cm(Gas-lift mechanism);
- Saddle seat design is more comfortable for changing posture with a wobble base than a common flat seat ;
- 55 kg/m³ density molded polyurethane foam;
- Fitted with non-slip rubber on the bottom;
- Non-slip base securely grips most floor surfaces;
- pull the strap from the front provide more convenience.
- Durable and abrasion-resistant polyester fabric cover (210g/m²).

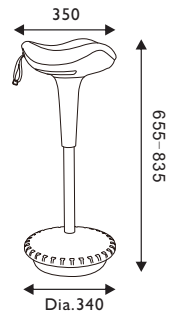

6139 TWIN Ergonomic Wobble Chair

Colours: 6939-1 Black 6939-5 Blue
6939-4 Red 6939-9 Grey



- Comfortable molded foam seat
- Seat covering fabric is made of high quality DARTEX of CA I 17 fire roof ;
- High quality Samhongsan non-swivel class 4 cylinder in chrome finish;
- Durable Convex Active Base covered with anti-slip rubber;
- Robust ABS Top Frame, Tube and Bottom Frame;
- 3 side height adjustable auto reset button provides super tactile feeling and convenient use.

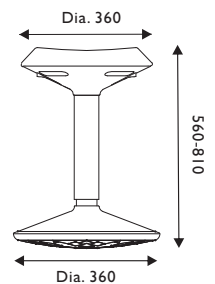

Ergonomic Wobble Chair

6137 TWIN Height Adjustable Wobble Stool

Colours: 6137-1 Black 6137-9 Grey
6137-5 Blue/White



- Comfortable molded foam (Thickness 50mm) seat;
- Seat covering fabric is made of high quality DARTEX of CAI 17 fire proof;
- High quality Samhongsaa non-swivel class 4 cylinder in chrome finish;
- Durable Convex Active Base covered with anti-slip rubber;
- Robust ABS Top Frame, Tube and Bottom Frame;
- Big lifting button provides super tactile feeling and convenient use.

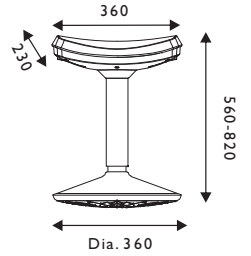

61516 / 61517 TWIN ACTIVE Wobble Stool - H14" / 17.75"

Colours:



- Soft EVA cushion on top;
- Orthopedic massage effect;
- Rubberized, non-slip bottom;
- Child safe, durable HDPE material.

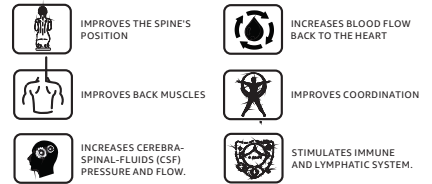

61516-1



61516-4



61516-5



61516-10

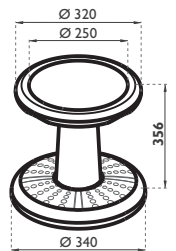

Height: 14"



61517-1



61517-4



61517-5



61517-10

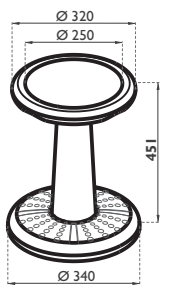

Height: 17.75"



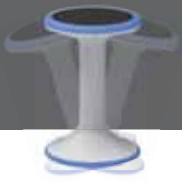

6160 TWIN Active Wobble Stool

Colours:



12" / 15" / 18" / 21"

4 heights settings



6160-2-9



6160-4-9



6160-10-9



6160-15-9



EPDM Pad Lycra fabric surface



Anti-Slippery Rubber Base



Customized colors available

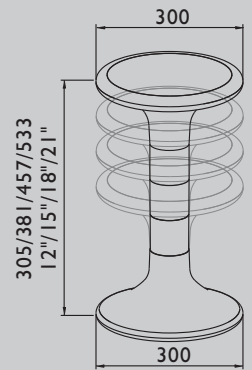

Domed Cushion

6161 TWIN Active Wobble Stool - With Domed Cushion



Flat Cushion

6162 TWIN Active Wobble Stool - With Flat Cushion



- Adjustable seat height between 12 and 21 inches.
- Integrated handles for easy carrying, even for smaller children.
- Tamper-proof height adjustments to prevent distractions.
- Angled base for improved posture, balance and stability.
- Soft, extra-thick cushion provides comfort and support for all-day use.

3161 TWIN TURN® Footrest

Colours: 3161-1 Black
3161-9 Grey

Reg. design: MR 2002 00822

- TWIN TURN® with two benefits:
 - One for stepless tilt support
 - A second with fixed support
- Room to move your feet

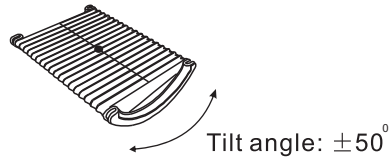
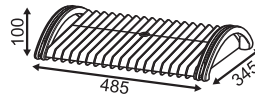

3111 TWIN ACTIVE Fodstøtte/ Footrest



Colours: 3111-1 Black
3111-5 Blue
3111-9 Grey

Reg. design: MR 1995 0662

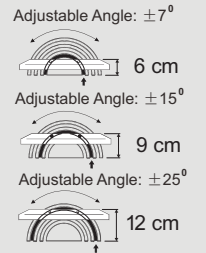
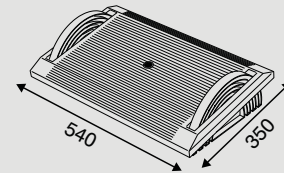

3131 TWIN FORM Footrest



Colour: 3131-1 Black

- Chromed metal frame
- Polystyrene footpad
- 4 non-slip feet prevent sliding
- Adjust angle by pressing lightly with your feet
- Easy adjusted to 4 different heights
- Easy to clean, easy to move

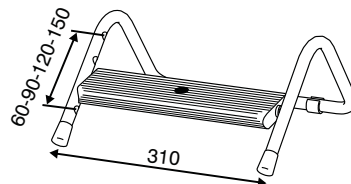

3121 TWIN ERGONOMIC Footrest



- Colour: 3121-I Black
- Chromed metal frame
 - Polystyrene footpad
 - 4 non-slip feet prevent sliding
 - Adjust angle by pressing lightly with your feet
 - Easy to clean, easy to move

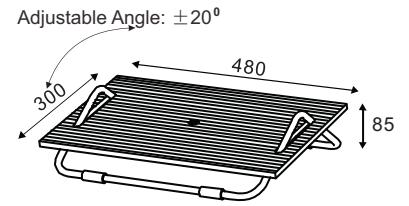

3151 TWIN PLUS Footrest



- ← 11 cm
- ← 9 cm
- ← 7 cm

- Colour: 3151-I Black
- Strong and steady
 - 3 easy height settings
 - 4 non-slip feet prevent sliding
 - Angle will follow the movement of your feet

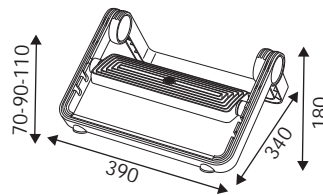

3181 TWIN Professional Footrest



- ← 15.5 cm
- ← 12.5 cm
- ← 9.5 cm

- Features 3 easy height setting mechanism;
- Foot-activating pivot provide perfect rotation force for foot exercise.
- Board made of robust plastic with anti-slip and massage strips;
- Sturdy power coated tubular steel construction;
- 4 none-slip rubber feet prevent sliding and make the construction very stable;
- Curved in angle to accommodate the chair and still sit close to the desk.

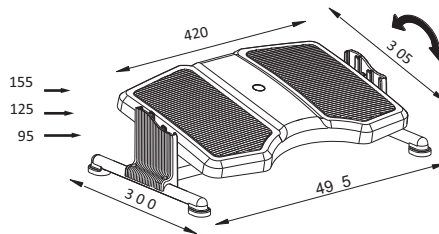

3182 TWIN PRO+ FOOTREST



- ← 15.5 cm
- ← 12.5 cm
- ← 9.5 cm

- Features 3 easy height setting mechanism;
- Foot-activating pivot provide perfect rotation force for foot exercise.
- Board made of robust plastic with anti-slip and massage strips;
- Sturdy power coated tubular steel construction;
- 4 none-slip rubber feet prevent sliding and make the construction very stable;
- Curved in angle to accommodate the chair and still sit close to the desk.

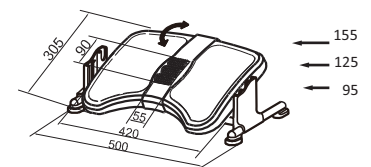

3171 TWIN Anti-Fatigue Footrest



3171-1

- Extra Load Weight & More Strong:
The product can weigh up to 70 kg . Heavy duty sturdy powder coated steel construction and;
- High quality ABS board and 4 none-slip rubber feet prevent sliding; Strong and Stable.
- Multifunction:
The footrest can not only massage but also add foam bar to make the legs more comfortable;
- Easy to use:
Height adjustable, 3 easy height settings;
Adjust angle by pressing your feet with perfect resistance;
Ultimate comfortable and supportive footrest.



3171-9

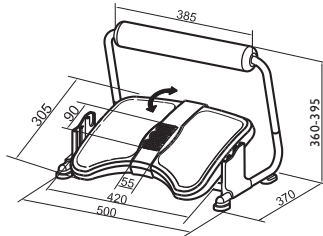

1WAY
Foot stool



2WAY
Foot
Massage



3WAY
Standing
Support



4WAY
Leg
Support



Massage
roller
Non-skid
rubber pad



Stable
rubber
foot



3.5cm height range

3191 TWIN RELAXING Footrest



3191-1

- Not only for foot exercise, but also for relaxing the legs;
- Features 3 easy height setting mechanism;
- Foot-activating pivot provide perfect rotation force for exercise;
- Board made of robust plastic with anti-slip and massage strips;
- Sturdy power coated tubular steel construction;
- 4 none-slip rubber feet prevent sliding and make the construction very stable;
- Curved in angle to accommodate the chair and still sit close to the desk.



3191-9



EASY
Height
Setting

Rotation resistance system
provide perfect force when swiveling.

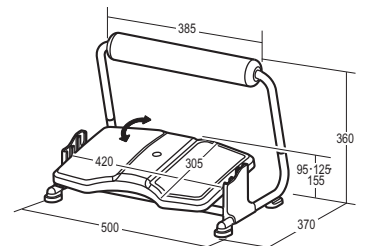

3.5cm height range

3176 TWIN RELAXING Footrest



- Relieving Plantar fasciitis**
 Whether you suffer from plantar fasciitis, aching heels, foot pain, sore arches, or neuropathy. This portable reflexology foot massage roller relieves your foot with a deep-tissue acupressure massage.
- Relax Your Feet and Legs**
 The foot roller massager doesn't just tackle plantar fasciitis, it also stimulates foot blood circulation. This is a lifesaver to relax and de-stress after a long day at work or running, fitness.
- Foot Ergonomically Designed**
 This ergonomic design foot massage roller fits the natural curvature of the feet arch, and increases comfort against any foot myofascial pain syndrome
- A Perfect Foot Gift**
 The foot massager targets relieve foot pain with acupressure reflexology technology. This foot massager is a practical gift for anyone suffering from plantar fasciitis or foot pain.

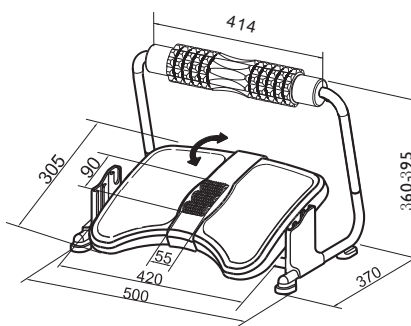
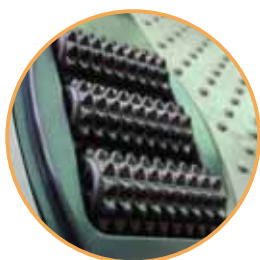

3187 TWIN Basic Foot Operation Footrest



- Hands Free Automatic Lifting system**
 Change height positions with effortless foot adjustment. No need to operate by hand. Allow you to go for the perfect height in seconds. It features a mechanical lifting system with a button-type height control, that can be operated with foot, allowing for easy and quick height adjustment.
- Large Infinitely Height Range**
 Large adjustable height range, from 125 mm to 320mm.
- Free or stationary angle adjustment**
 Platform can be fixed in any position from 0 to 40° or free for tilting adjustment according foot pressure on the plate. Experience precise ergonomics with dynamic, free movement or stationary support across multiple postures.
- High load capacity**
 Max. load capacity 100 kg.
- Multi-Function**
 people can also use the footrest as a laptop table / a chair / a stepstool etc.

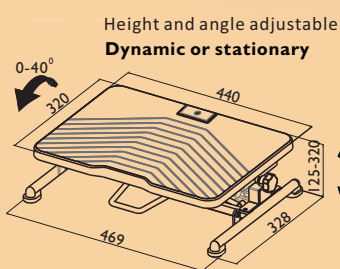



3186 TWIN Pro Foot Operation Footrest

Gas Lift System



- **Hands Free Automatic Lifting system**
Change height positions with effortless foot adjustment. No need to operate by hand. Allow you to go for the perfect height in seconds. It features a smoother pneumatic lifting system with a button-type height control, that can be operated with foot, allowing for easy and quick height adjustment.
- **Large Infinitely Height Range**
Large adjustable height range, from 80 mm to 300mm.
- **Free or stationary angle adjustment**
Platform can be fixed in any position from 0 to 40° or free for tilting adjustment according foot pressure on the plate. Experience precise ergonomics with dynamic, free movement or stationary support across multiple postures.
- **High load capacity**
Max. load capacity 100 kg.
- **Multi-Function**
people can also use the footrest as a laptop table / a chair / a stepstool etc.



3186P - TWIN Pro Gas lift Footrest with Soft Pad

Soft Pad



- Comes with a soft pad top for soft supportive comfort.
- Elastic band let you swap to a different material easily.
- Let you customize your sitting experience further — choose from different options to suit your preferences.
- With high friction underside, the soft pad won't slide easily.



Height and angle adjustable

Dynamic or stationary

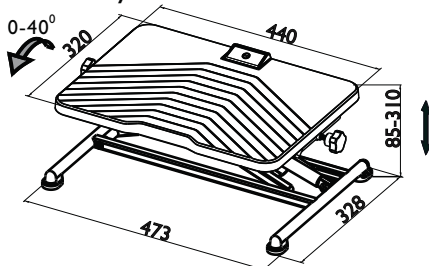

3186

Dynamic or stationary

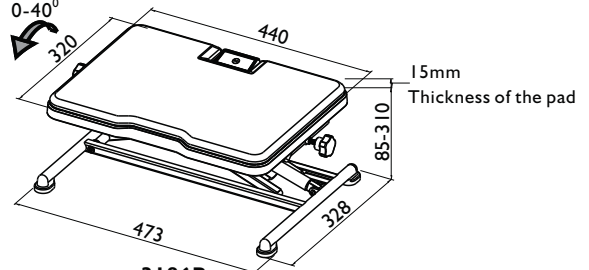

3186P

15mm
Thickness of the pad



3177 TWIN Versatile Seat to Footrest

As a footrest



As a seat

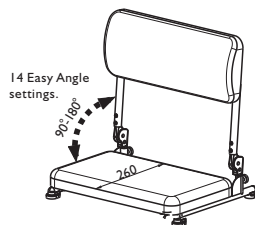
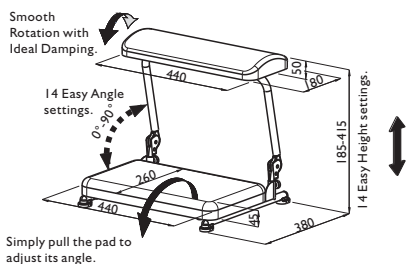

- **Versatile Design** - The portable seat can be easily converted into an ergonomic footrest.;
- **Easy adjustment** - Smart mechanical adjustment for optimal comfort. This system allows you to effortlessly set your preferred height and angle in seconds;
- **Large Height Range** - Large adjustable height range, from 185 mm to 415mm;
- **Compact & Easy to Carry** - All-in-One Seat Lets You Sit Down & Pack Up & Go in Seconds!
- **Comfortable soft cushion** - T30mm High-Density Sponge Cushion with High Quality PU Leather covering ;
- **Sturdy and Stable Support:** Thanks to its durable steel frame and non-slip feet.
- Max. load capacity 100 kg;
- Colours: 3177-1 Black
3177-2 White

Folding seat



ERGONOMIC FOOTREST



EASY PORTABILITY



Easy-angle adjustment



3157 TWIN Massage & Relaxation Footrest



- **2-in-1 footrest** - This 2-in-1 footrest offers a massage roller on one side and a sponge pad with High Quality PU Leather covering on the reverse. Simply flip it over to switch functions.
- **Relieving Plantar fasciitis:** Deep Tissue Relief for Heel & Arch Pain, Reflexology & Improved Circulation;
- Larger Durable Wooden Design with Smooth Finish: Made from eco-friendly solid wood;
- **Relax Your Feet and Legs**
The foot roller massager doesn't just tackle plantar fasciitis, it also stimulates foot blood circulation. This is a lifesaver to relax and de-stress after a long day at work or running, fitness.
- Non-Slip Base for Safe Use;

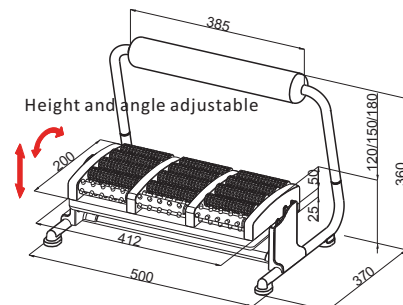



3153 TWIN Rocking Ergonomic Footrest



- **2-in-1 footrest** - This 2-in-1 footrest offers a massage roller on one side and a sponge pad with High Quality PU Leather covering on the reverse. Simply flip it over to switch functions.
- **Relieving Plantar fasciitis:** Deep Tissue Relief for Heel & Arch Pain, Reflexology & Improved Circulation
- Larger Durable Wooden Design with Smooth Finish: Made from eco-friendly solid wood;
- **Relax Your Feet and Legs** - The foot roller massager doesn't just tackle plantar fasciitis, it also stimulate foot blood circulation. This is a lifesaver to relax and de-stress after a long day at work or running, fitness.
- Height and angle adjustable;
- Non-Slip rubber ring for Safe Use;

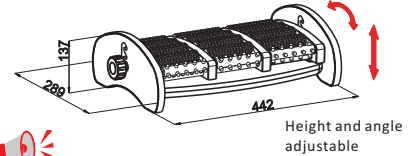

3152 TWIN Rocking Ergonomic Footrest



- **Premium Wooden Construction:** Crafted from high-quality natural solid wood;
- **Anti-slip Features:** anti-slip strips on the platform and non-slip pads on the base, ensuring stability ;
- **Rocking Ergonomic Foot Stool:** This Foot Rest provides premium comfort during prolonged sitting by encouraging gentle rocking of the feet

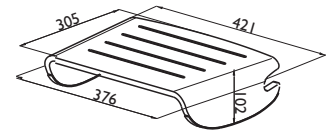

3154 TWIN Rocking Ergonomic Footrest



- **Premium Wooden Construction:** Crafted from high-quality natural solid wood;
- **Enhanced Massage & Anti-slip Features:** Built-in massage rollers provide therapeutic relief for tired feet. Includes DIY anti-slip strips for the foot; platform and pre-installed non-slip pads on the base, ensuring stability on any floor surface - from hardwood to carpet;
- **Rocking Ergonomic Foot Stool:** This Foot Rest provides premium comfort during prolonged sitting by encouraging gentle rocking of the feet;
- **Smooth Gliding Experience:** This glider foot rest allows you to engage lower leg muscles, designed with ball bearing rollers that help you feel like you're gliding weightlessly through your work day;
- **High End Construction:** constructed with a durable steel frame, non-skid pads to keep your feet in place, and rubber feet to protect your floors;
- **Height adjustable.**

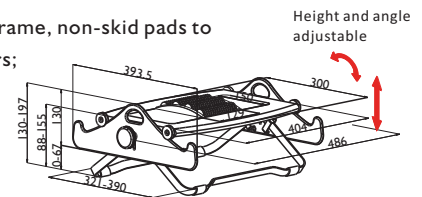

3172 TWIN PORTABLE Footrest



- Foot board made of robust and durable steel;
- Foot board covering is anti-slip and hardwearing felt pad;
- Heavy duty sturdy powder coated steel construction;
- Handle is covered with soft foam for comfort use;
- 4 none-slip rubber feet prevent sliding; Strong and Stable;
- Big range of height adjustment, 6 easy height settings.

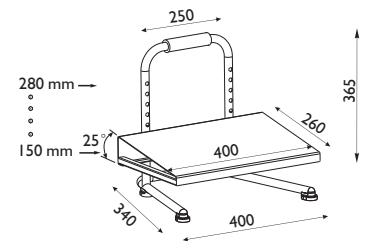

3183 / 3193 TWIN ERGO PLUS Footrest



- Foot board made of robust and durable steel;
- Foot board covering is anti-slip and hardwearing felt pad;
- Heavy duty sturdy powder coated steel construction;
- 4 none-slip rubber feet prevent sliding; Strong and Stable;
- Height adjustable, 3 easy height settings;
- Adjust angle by pressing your feet with perfect resistance;
- Unique rotation resistance system provide perfect force when swiveling by feet.

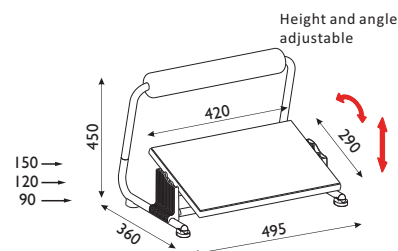

3184 3185 TWIN Soft Pad Footrest



3184



3185



3 easy height setting



3184A



3185A



Soft polyester fabric

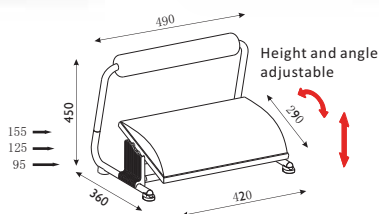

- Ultimate comfortable and supportive footrest;
- Heavy duty sturdy powder coated steel construction;
- 4 none-slip rubber feet prevent sliding; Strong and Stable;
- Height adjustable, 3 easy height settings;
- Adjust angle by pressing your feet with perfect resistance;
- Unique rotation resistance system provide perfect force when swiveling by feet.
- Premium high density memory foam which will easily conform to the shape of any size feet



TWIN Ergonomic Heating Footrest



3184T



3184AT



3185T



3185AT

- **Stable Heat:** The heating forearm support uses a wired design with 13W power to deliver consistent, reliable warmth;
- **Fast Heating:** The heating forearm support features quick-heating technology to minimize your wait time. It offers 3 temperature settings, allowing you to customize warmth to your preference;
- **Make you feel comfortable:** This heating pad can relieve pain discomfort and provide ample heat to your feet. It provides a comfortable warming experience and keeps you warm at all times;
- **Stable and Comfortable Material:** Soft polyester fabric covering. 30D inner high density foam; this heating footrest is made of soft, comfortable and durable materials to provide supper comfort;
- **Auto-off feature:** Your heating pad includes auto-off feature. 60-120 min auto shut-off function allowing you to enjoy warmth without worrying about accidentally leaving it on.
- **Cable included:** Universal USB and type C Cable included;
- **CE certified.**



Type C port



100% power



70% power



50% power



3194 / 3195 / 3196 / 3197 / 3198 / 3199

TWIN Multi-functional Footrest

- Ultimate comfortable and supportive footrest;
- Premium high density foam with faux leather covering.;
- Faux Leather has good soft elasticity, abrasion resistance and scratch resistance;
- Adjust angle by pressing your feet with perfect resistance;
- Unique rotation resistance system provide perfect force when swiveling;
- Heavy duty sturdy powder coated steel construction;
- 4 none-slip rubber feet prevent sliding; Strong and Stable;
- Height adjustable, 3 easy height settings.

3194

Colour: 3194-1 Black
3194-2 Light Grey

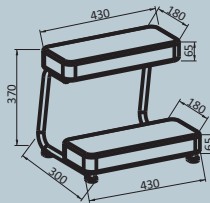

3195

Colour: 3195-1 Black
3195-2 Light Grey

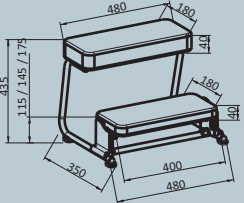

3196

Colour: 3196-1 Black
3196-2 Light Grey

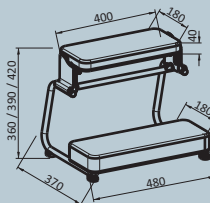

3197

Colour: 3197-1 Black
3197-2 Light Grey

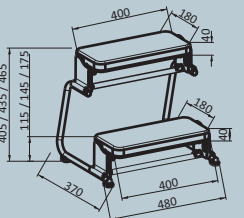
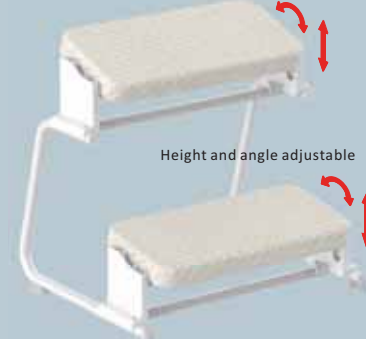

3198

Colour: 3198-1 Black
3198-2 Light Grey

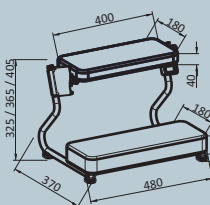

3199

Colour: 3199-1 Black
3199-2 Light Grey

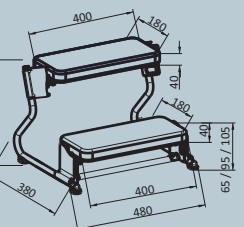

4100 TWIN Versatile Ball Chair



- Versatile: Simply use the ball as a chair replacement or integrate it with a variety of efficient yoga exercises;
- Stable and Safe: Anti-burst technology with smart honeycomb structure that prevent bursting of the environmentally friendly material;
- The ball chair is designed for a maximum user weight of 250 lb;
- Removable Cover: Easily cleanable and durable fabric cover can be easily removed for washing, ensuring easy maintenance and prolonged usage;
- Package Including: 1x inflator, 1x Cover, 1x PVC Ball, 1x Valve Core, 1x Manual.

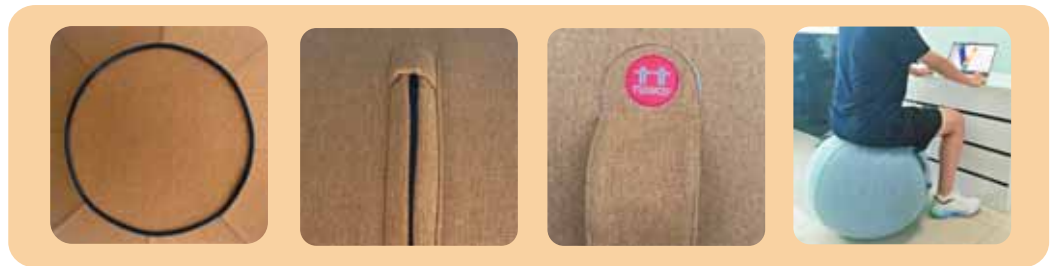

3192 TWIN Anti-Fatigue Balance Board



- Smart, ergonomic design: Our standing balance board slides under your desk at home or at work to let you tilt, lean, and remain steady with an 8.5° tilting angle;
- Non-skid standing surface: Each stability rocker is made with natural hardwood, an anti-slip pure PU layer to keep feet in place, and an anti-scratch rubber base;
- Trigger point foot massage: The top features textured pressure points that gently massage away soreness to keep feet feeling energized.
- Portable accessory: Easy to carry; Non-toxic & Odorless.

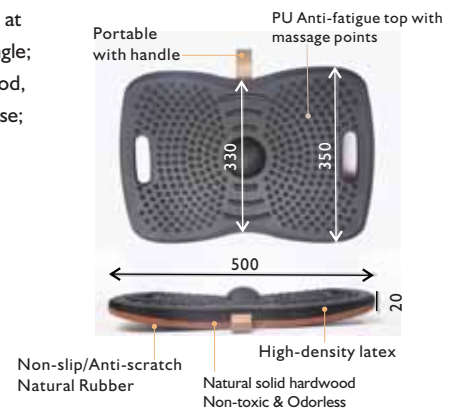

TWIN Hard floor Chair Mat / Carpet Chair Mat



43011 / 43013



43012 / 43014

Size - Hard floor Chair Mat:
43011: 1500x1200x1.5 mm
43013: 1200x1000x1.5 mm

Size - Carpet Chair Mat:
43012: 1500x1200x1.5 mm
43014: 1200x1000x1.5 mm

- **CHAIR MAT FOR FLOOR PROTECTION:** This office chair mat is designed to protect floors or carpet from scratches and dirt, providing a larger area of protection for your office area, suitable for your home or office. (43011 for hard floor and 43012 for carpet)
- **ODORLESS, NON-TOXIC:** Office clear floor mats are BPA free and phthalates, non-toxic and harmless, which can create a healthy and safe indoor environment. The office chair floor mats will not crack, curl or break in daily use.
- **NON-SLIP SURFACE TEXTURE:** The surface of the rolling chair mat has a special texture that makes it easy for chairs to roll, helping to reduce leg fatigue for sedentary people and providing a comfortable working and studying experience.
- **HIGH TRANSPARENCY:** The transparent design of the plastic floor mats for office chairs allows you to show off the beauty of hard floors. The PVC material is easy to clean, just use a damp cloth to clean it.



Snapframes / Plakatrahmen

Mobile Whiteboard

Flip Chart / Flipchart

Whiteboard

Cork board / Kork board

Felt board / Filz board

Glass Whiteboard / Glas Whiteboard

Flip Chart with glass whiteboard / Flipchart mit glas whiteboard

Mobile Glass Whiteboard / Mobile Glas Whiteboard

5330 & 5331 TWIN AGENDA A Boards



5330

A Board, 70x100
 Colour: 5330-11 Alu.
 Alu frame, 32 mm wide

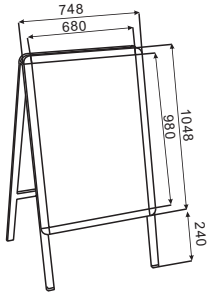

5331

A Board, 70x50
 Colour: 5331-11 Alu.
 Alu frame, 32 mm wide

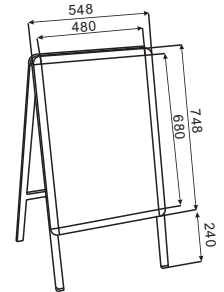

5366 TWIN Mobile Water Base Poster Frame



- Aluminum Snapframe;
- Poster Frame Size: A1, 840x594mm, double sides;
- Base size: 785x490x160mm;
- Base capacity: 23L water or sand for stability;
- With two wheels on the bottom and a handle for portable use.

Container cap



Handle



2 wheels on the bottom



5366-8



5366-1

5175 TWIN AGENDA A4 & 5176 TWIN AGENDA A3 Literature Display with snapframe



Colour: 5175-8 Silver
 Format: A4
 W: 252 mm
 H: 900 mm
 D: 235 mm

- Showcase your message
- Snapframe for easy replacement
- This sign is easily rotated from portrait to landscape

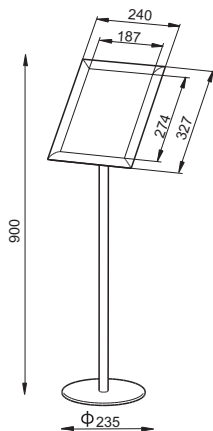

Colour: 5176-8 Silver
 Format: A3
 W: 340 mm
 H: 930 mm
 D: 280 mm

- Showcase your message
- Snapframe for easy replacement
- This sign is easily rotated from portrait to landscape

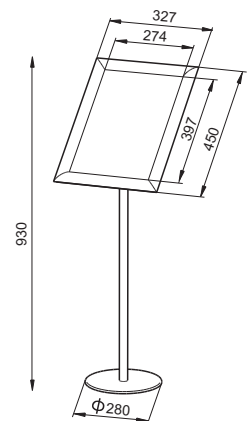

AGENDA Snaprammer/ Snapframes



5312
Snapframe, A3
Colour: 5312-11 Alu.
Aluminum frame, 25 mm wide
W:343 mm D:11,5 mm H:465 mm



5310
Snapframe, A5
Colour: 5310-11 Alu.
Aluminum frame, 25 mm wide
W:193 mm D:11,5 mm H:253 mm



5311
Snapframe, A4
Colour: 5311-11 Alu.
Aluminum frame, 25 mm wide
W:255 mm D:11,5 mm H:340 mm

5320
Snapframe, 70 x100
Colour: 5320-11 Alu.
Aluminum frame, 32 mm wide
W:760 mm D:18 mm H:1060 mm

5321
Snapframe, 70x50
Colour: 5321-11 Alu.
Aluminum frame, 32 mm wide
W: 560 mm D:18 mm H: 760 mm

TWIN LIGHT Snaprammer/ Snapframes

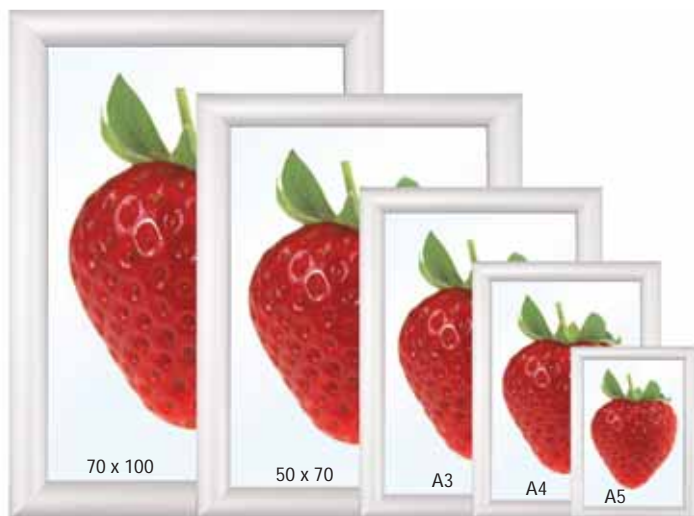

Mitred corners /Eloxierter Alu-profil

5352-11
Snapframe, A5
Colour: 5310-11 Alu.
Aluminum frame, 25 mm wide
W:193 mm D:11,5 mm H:253 mm

5342-11
Snapframe, A4
Colour: 5342-11 Alu.
Aluminum frame, 25 mm wide
W:255 mm D:11,5 mm H:340 mm

5343-11
Snapframe, A3
Colour: 5343-11 Alu.
Aluminum frame, 25 mm wide
W:343 mm D:11,5 mm H:465 mm

5351-11
Snapframe, 70 x100 B1
Colour: 5320-11 Alu.
Aluminum frame, 32 mm wide
W:760 mm D:20 mm H:1060 mm

5353-11
Snapframe, 70x50 B2
Colour: 5321-11 Alu.
Aluminum frame, 32 mm wide
W: 560 mm D:20 mm H: 760 mm

5354-11
Snapframe, 118x83 A0
Colour: 5354-11 Alu.
Aluminum frame, 32 mm wide
W: 1240 mm D:20 mm H: 890 mm

5484 5485 5486 5487 Showcase /Vitrine



- Wall mounted;
- Dry erase, Magnetic surface;
- Aluminum frame;
- Acrylic door;
- With accessories and mounting kits

Size :		
5484	670x500 mm	4xA4
5485	670x720 mm	6xA4
5686	980x720 mm	9xA4
5487	1200x900 mm	12xA4

5467 5468 5469 TWIN Mobile Whiteboard



Double sided magnetic surface
 Board 360° revolves and locks automatically
 Four locking castors for easy mobility
 large pen tray included

5467
 Whiteboard: 1500x1200 mm
 5468
 Whiteboard: 1200x900 mm
 5469
 Whiteboard: 1800 x 1200 mm

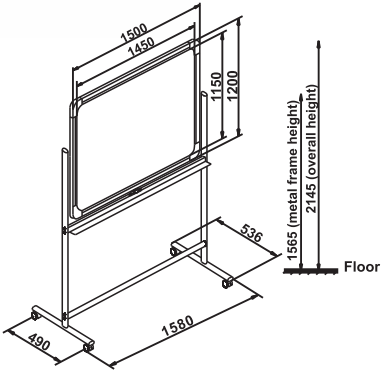

5467

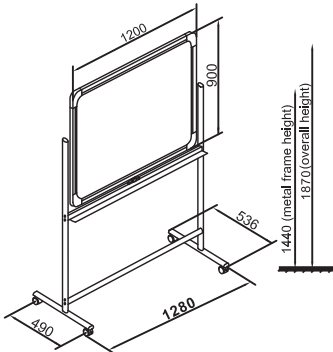

5468

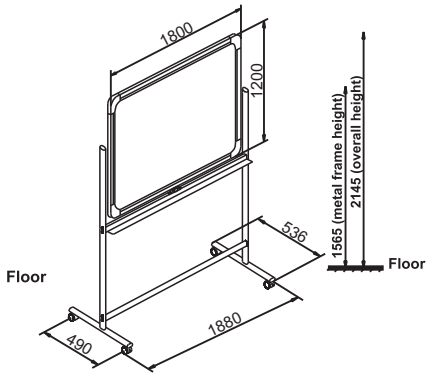

5469

TWIN Foldable Whiteboard

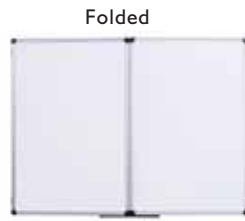

- Foldable design;
- 5 writing surfaces;
- Wall mounted;
- Dry erase, Magnetic surface;
- Aluminum frame;
- With pen tray and accessories.

Size:

5511-11: 900x600 / 600x450 mm
 5512-11: 1200x900 / 900x600 mm
 5513-11: 1500x1000 / 1000x750 mm
 5514-11: 1500x1200 / 1200x750 mm
 5515-11: 2000x1200 / 1200x1000 mm

5441 TWIN Flip Chart/ Flipchart



Magnetic whiteboard with ABS frame. Adjustable paper clamp. Tripod metal stand in grey. Easy to assemble and adjustable height. Full length metal pen-tray. Whiteboard size: 650 x 1000

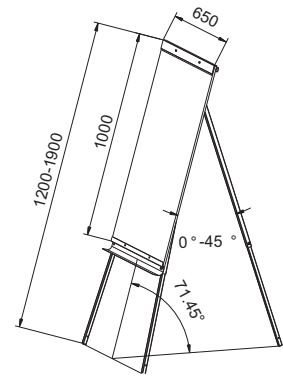

5442 TWIN Mobile Flip Chart



Magnetic whiteboard with ABS frame. Adjustable paper clamp. Mobile metal stand in grey. Five locking castors for easy mobility. Easy to assemble and adjustable height. Full length metal pen-tray. Whiteboard size: 1000 x 650 mm

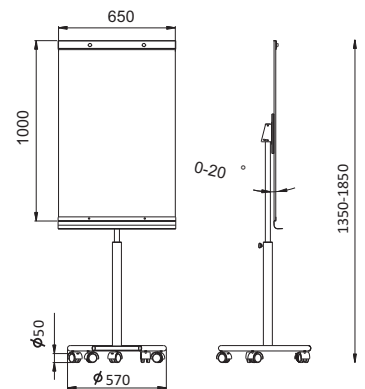



TWIN MEMO Rail

Size:
 MMR 030: 300mm;
 MMR 050: 500mm;
 MMR 100: 1000mm;
 MMR 120: 1200mm;
 MMR 150: 1500mm;



- Durable Construction – high-quality aluminum alloy, which is durable, wear-resistant, corrosion-resistant, not easy to deform, safer, and does not hurt the hand. The control lever is very sturdy, lightweight;
- Easy Poster Change – The receipt holder prevents the receipt from falling off the clip, you can slide the receipt onto the rail safely and easily, and it is easy to take out without tearing, and the receipt is firmly fixed to the rail;
- Easy to Install – Strong adhesive backing or screws, firmly adhered.

5445 TWIN Flip Chart with Memo Rail

- Easy Poster Change - with aluminum Memo Rail on the top;
- Magnetic whiteboard with ABS frame;
- Adjustable paper clamp;
- Tripod metal stand in grey;
- Easy to assemble and adjustable height;
- Full length metal pen-tray.

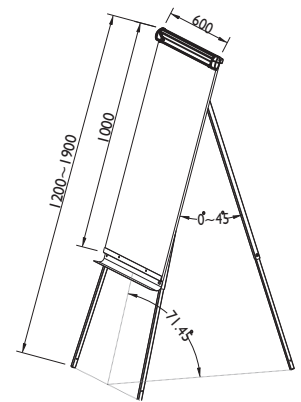

5446 TWIN Flip Chart with Memo Rail

- Easy Poster Change - with aluminum Memo Rail on the top;
- Can also be a table when the whiteboard is laid flat;
- Magnetic whiteboard with ABS frame;
- Adjustable paper clamp;
- Mobile metal stand in grey;
- Easy to assemble and adjustable height;
- Full length metal pen-tray.

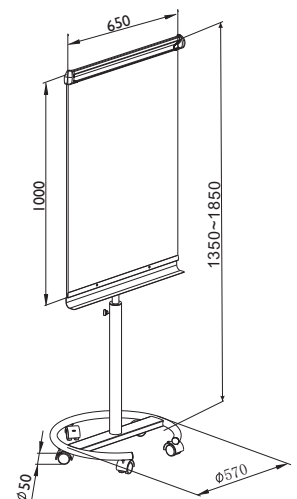

TWIN Whiteboard



Coated steel sheet surface
Magnetic surface
Aluminum frame,
ABS corner. Wall mounted
Wall mounting kit included
Pen tray
Size:
5410-11: 600x450 mm
5411-11: 900x600 mm
5412-11: 1200x900 mm
5414-11: 1500x1000 mm
5415-11: 1800x900 mm
5416-11: 1800x1200 mm



TWIN Kork opslagstavle/Cork board/Kork board



Self-healing resilient cork
For use with pushpins
Wall mounting kit included
Size:
5431-12: 600x450 mm
5432-12: 900x600 mm
5433-12: 1200x900 mm
5434-12: 1500x1000 mm
5435-12: 1800x900 mm
5436-12: 1800x1200 mm



TWIN Filz opslagstavle/ Felt Board/ Filz taflen



Popular aluminium framed felt noticeboards Smooth felt surface available in a choice of four colours. Perfect setting for enhancing your communication classic anodized aluminium frame
Concealed wall fixings through plastic corners.
Wall mounting kit included

5452 900 x 600 mm	5453 1200 x 900 mm
Colours	Colours
5452-9 Grey	5453-9 Grey
5452-5 Blue	5453-5 Blue
5454 1500 x 1000 mm	5459 1800 x 1200 mm
Colours	Colours
5454-9 Grey	5459-9 Grey
5454-5 Blue	5459-5 Blue

TWIN Magnetic Lacquered Chalk board

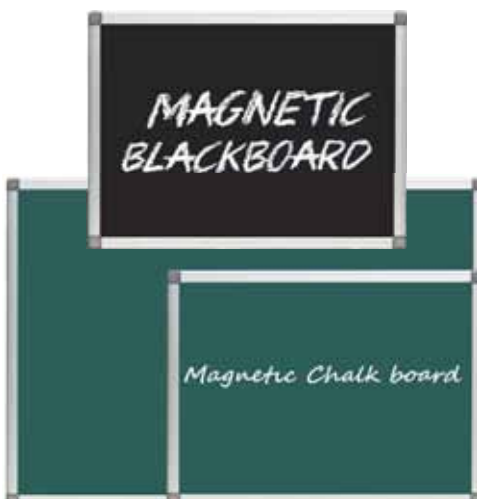

Coated steel sheet surface
Magnetic surface
Aluminum frame,
ABS corner. Wall mounted
Wall mounting kit included
Pen tray

5491 900x600 mm	5492 1200x900 mm
Colours	Colours
5491-1 Black	5492-1 Black
5491-10 Green	5492-10 Green
5494 1500x1000 mm	5496 1800x1200 mm
Colours	Colours
5494-1 Black	5496-1 Black
5494-10 Green	5496-10 Green

TWIN Mobile Glass Flipchart/Mobile Glas-Flipchart



- Mobile, height adjustable stand with circular base.
- 4mm thickness tempered glass white board; Back side - Zink plated steel;
- Dry erase; Magnetic writing surface;
- Height adjustable; Angle adjustable;
- With paper hooks; With acrylic pen tray, magnets and eraser;
- 5 lockable and durable mute castors for easy stability.
- Flat pack in strong honeycomb carton; easy self assembly.

Size/Format: 5642 900x600 5643 1000x700

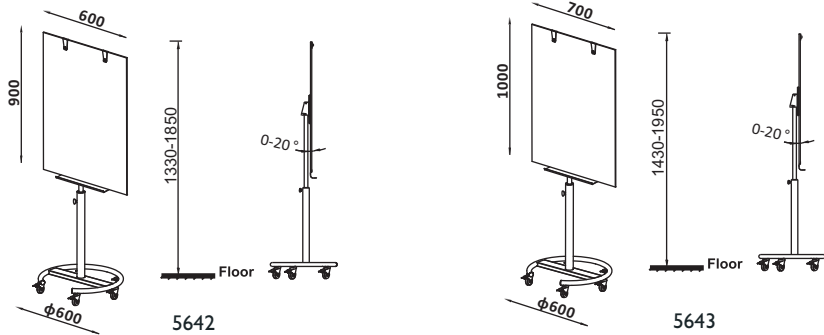

TWIN Mobile Glass Whiteboard/Mobile Glas Whiteboard

- Heavy duty black power coated steel construction;
- 2PCS 4mm thickness tempered glasses with zink plated steel in the middle;
- 360 Degree rotation white board;
- Dry erase, Magnetic writing surface;
- With acrylic pen tray, magnets and eraser;
- Four lockable and durable mute castors for easy stability;
- Flat pack in strong honeycomb carton; easy self assembly.

Size/Format: 5662 1200x900 5663 1500x1000

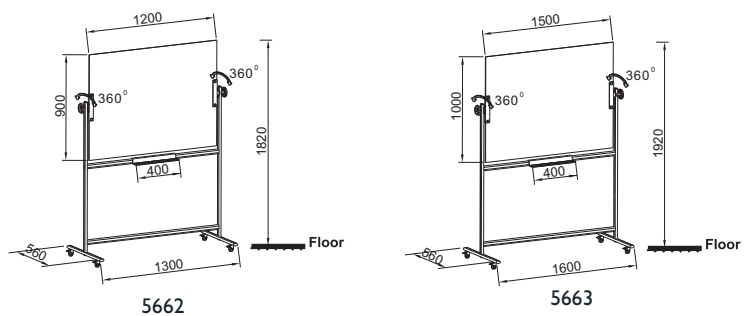

Glass Whiteboard/Glas-Whiteboard

TWIN Glass Whiteboard/Glas-Whiteboard



- 4mm tempered glass;
- Wall mounted;
- Dry erase, Magnetic surface;
- Back side - Zink plated steel.
- With acrylic pen tray;
- With accessories and mounting kits;
- Flat pack in strong honeycomb carton.

Size:

5608	1200x800	5614	1500x1000
5610	600x450	5615	2000x1000
5611	900x600	5616	2000x1200
5612	1200x900	5617	2400x1200

TWIN Glass Whiteboard with frame/Glas Whiteboard mit Rahmen

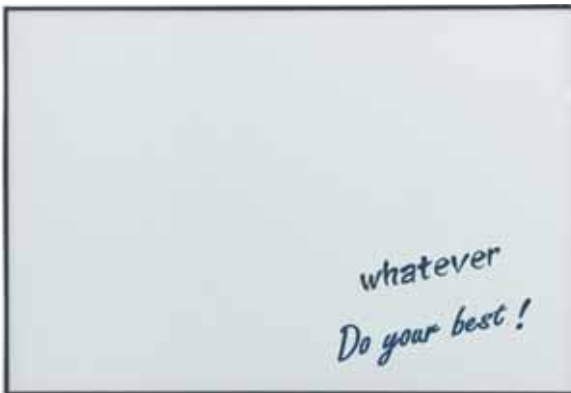

- 4mm tempered glass;
- Black aluminum frame;
- Wall mounted;
- Dry erase, Magnetic surface;
- Back side - Zink plated steel.
- With aluminum pen tray;
- With accessories and mounting kits;
- Flat pack in strong honeycomb carton

Size:

5621	900x600	5624	1500x1000
5623	1200x900	5625	2000x1000

5631 TWIN Flip Chart with Glass Whiteboard/Flipchart mit Glas Whiteboard



- A-type Stand Flipchart
- White board size: 900X600 mm;
- 4mm tempered glass;
- With black aluminum frame;
- Back side - Zink plated steel;
- Dry erase, Magnetic writing surface;
- With aluminum pen tray;
- With magnets and eraser;
- Flat pack in strong honeycomb carton.

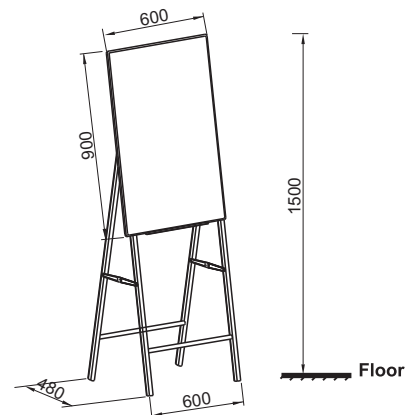



Literature Holders/ Bodenständeren
Acrylic Displays/ Acryl Prospekthalter
Belt Barrier systems/ Gurtpfosten mit ausziehbarem

AGENDA - For elegant presentations

5108 Wall mount

1/3 A4, 6 comp.
Colour: 5108-8 Silver
B: 115 mm D: 75 mm H: 775 mm

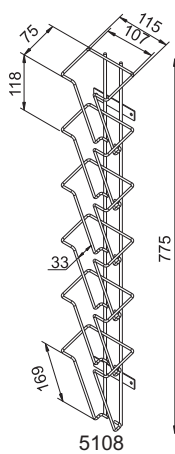

5109 Wall mount

A5/A6, 9 comp.
Colour: 5109-8 Silver
W: 165 mm D: 75 mm H: 780 mm

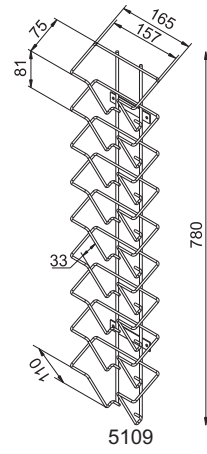

5110 Wall mount

A5, 9 comp.
Colour: 5110-8 Silver
W: 165 mm D: 75 mm H: 780 mm

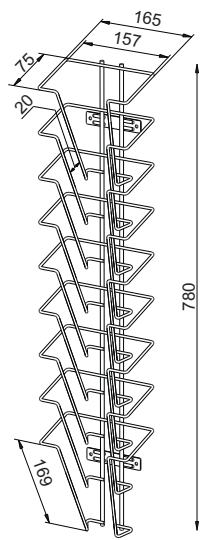

5111 Literature Holder

Table model A4, 1 comp.
Colour: 5111-8 Silver
W: 230 mm D: 103 mm H: 275 mm
Package contains 10 pcs.

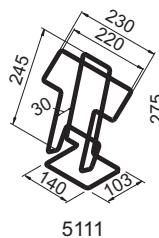

5112 Literature Holder

Wall model, A4, 1 comp.
Colour: 5112-8 Silver
W: 230 mm D: 75 mm H: 252 mm
Package contains 10 pcs.

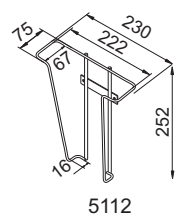

5115 Table top revolving stand

A4, 9 comp.
Colour: 5115-8 Silver
D: 300/315 mm H: 550 mm

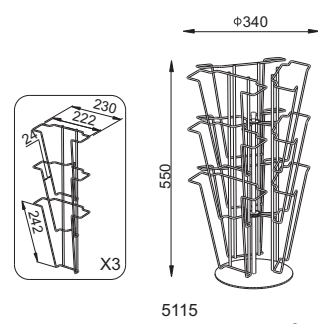

5120 Wall mount

A4, 15 comp. Wall fittings enclosed
Colour: 5120-8 Silver
W: 710 mm D: 75 mm H: 780 mm

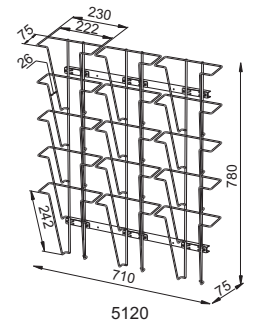

5140 Wall mount

A4, 6 comp.
Colour: 5140-8 Silver
W: 235 mm D: 75 mm H: 780 mm

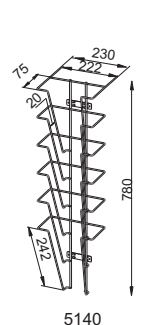

5150 Wall mount

A4, 10 comp.
Colour: 5150-8 Silver
W: 230 mm D: 75 mm H: 1160 mm

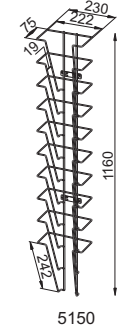

5190 Newspaperholder

Colour: 5190-8 Silver
Wall model A3, 5 comp.
W: 436 mm D: 75 mm H: 780 mm





5110



5140



5150



5112



5111



5190



5120



5115

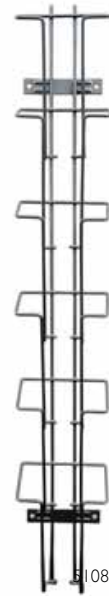

5108



5109



5121 / 5122 TWIN Floor Stand Literature Holder

- 6x44 (5121) / 12x44 (5122) comp.;
- Foldable brochure stand;
- Deep pockets depth - 43 mm, Suitable for thicker catalogs, etc.;
- Quick to fold;
- Powder coated steel material in silver color;
- With anti-slippery pads on the bottom;
- Flat packing. No need to be assembled.

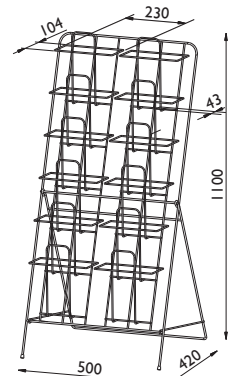
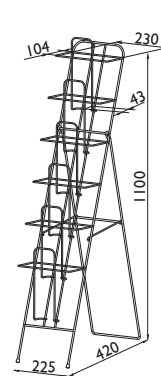

5122-8



5121-8

AGENDA Newspaper Stand/Zeitungshalter - Literature Holder/Prospekthalter

5180 & 5170 TWIN AGENDA TABLOID Avisstander/ Newspaper Stand/Zeitungshalter



- Colour: 5180-8 Silver
- Elegant in metal colour
 - Strong and stable
 - Showcase your message
 - Elegant in metal colour

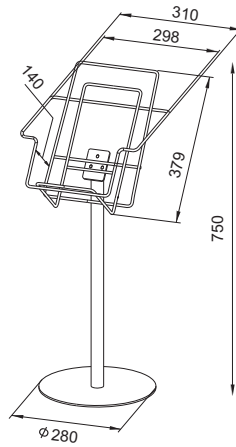

- Colour: 5170-8 Silver
Format: A4, 1 comp.
Space for 75 mm
- Showcase your message
 - Elegant in metal colour
 - Strong and stable

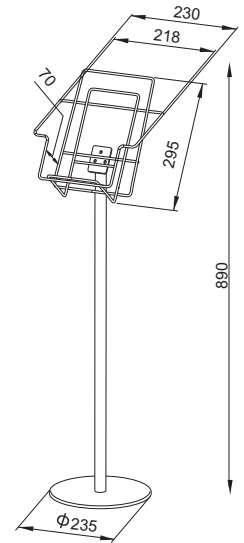

5130 & 5135 TWIN AGENDA Literature Holder/Prospekthalter



- Colour: 5130-8 Silver
A4, 32 comp.
- Revolving floor stand
 - Elegant in metal colour
 - Strong and stable

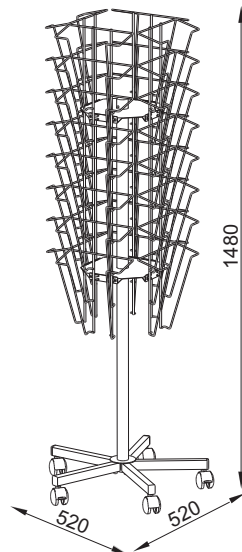

- Colour: 5135-8 Silver
A4 15 comp.
D: 280 mm H: 1500
- Revolving floor stand

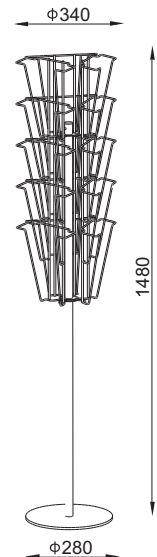

AGENDA Newspaper Stand/Zeitungshalter - Literature Holder/Prospekthalter

5181, 5182, 5183, 5184 TWIN Brochure display stands



Colour: Silver

- Strong and stable
- Shelves at 45 angle
- 40mm stop edge to hold more documents
- Mobile on 4 lockable swivel casters



Model	5181	5182	5183	5184
Capacity	4 x A4	12 x A4	16 x A4	20 x A4

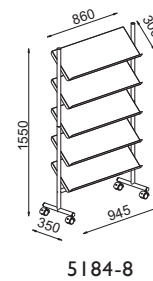
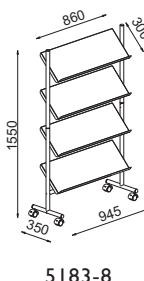
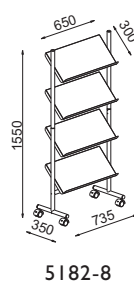
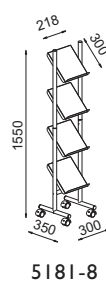

5172 & 5173 TWIN Brochure display holder



Model	5172	5173
Capacity	7 x A4	5 x A4

Colors: 5172-1 Black
5173-1 Black
5172-8 Silver
5173-8 Silver

- Elegant in metal colour
- Strong and stable
- Showcase your message
- Wall mounting

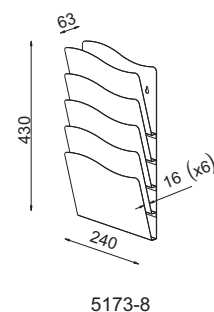
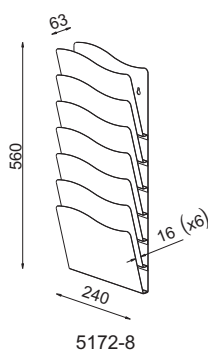

5116&5136 TWIN AGENDA Literature Holder/Prospekthalter

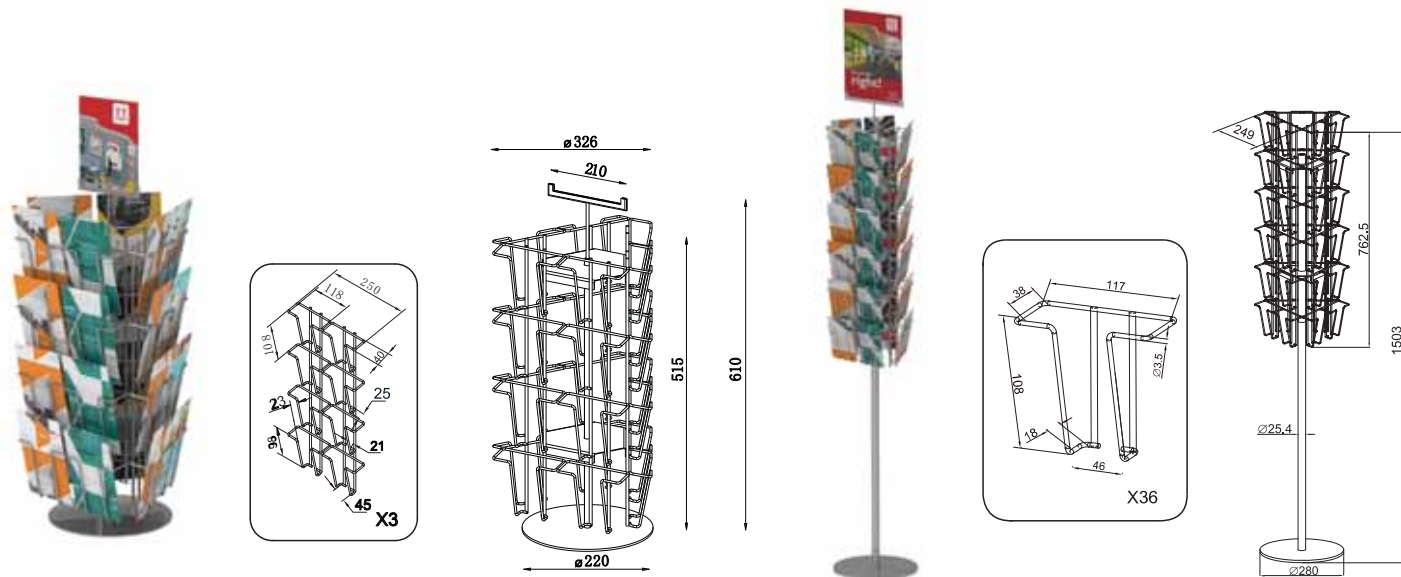

5171 TWIN Presentation Stand

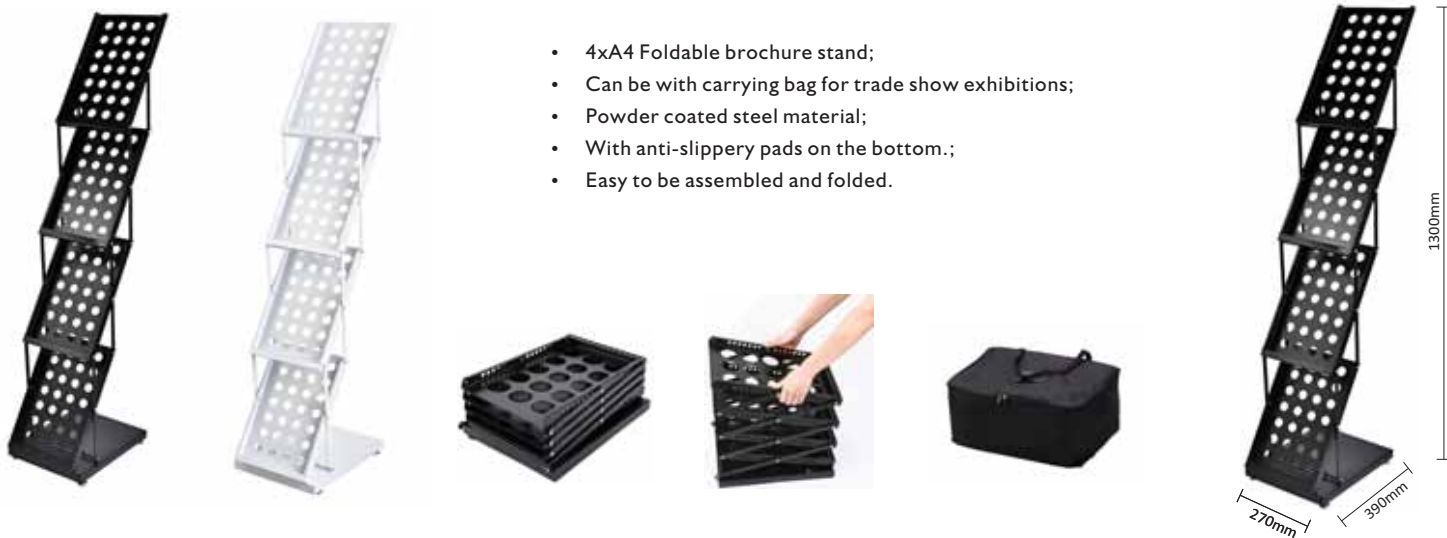

- 4x4 Foldable brochure stand;
- Can be with carrying bag for trade show exhibitions;
- Powder coated steel material;
- With anti-slippery pads on the bottom.;
- Easy to be assembled and folded.

5174 TWIN Presentation Stand

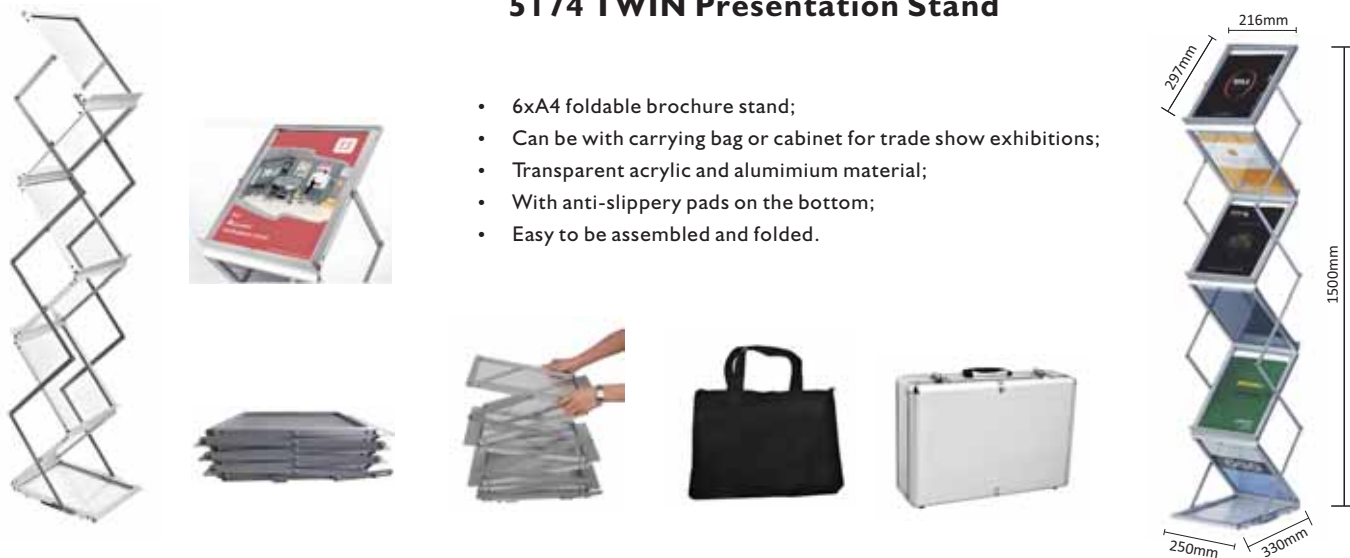

- 6x4 foldable brochure stand;
- Can be with carrying bag or cabinet for trade show exhibitions;
- Transparent acrylic and aluminium material;
- With anti-slippery pads on the bottom;
- Easy to be assembled and folded.

2017 TWIN METAL Penneholder/Pen Holder/ Stifteköcher



Colours: 2017-1 Black
2017-8 Silver
Height: 100 mm
Dia: 87 mm

- Elegant in metal colours
- Stable pen holder in a nice design and good quality

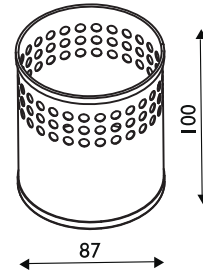

2010 TWIN METAL Waste Bin 15 L



Colours: 2010-1 Black
2010-8 Silver
Capacity: 15 L
Height: 320 mm
Dia: 258 mm

- Elegant in metal colours
- Stable waste bin in a nice design and good quality

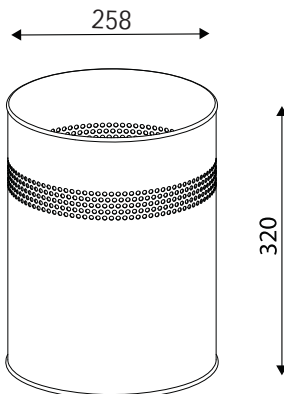



2040 TWIN METAL Waste Bin 21 L

- Colours: 2040-1 Black
2040-8 Silver
- Capacity: 21 L
Height: 460 mm
Dia: 260 mm
- Elegant in metal colours
 - Strong and stable

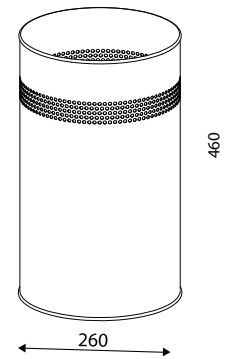

2060 TWIN METAL Waste Separator



- Colour: 2060-1 Black
Height: 130 mm

- Insert for separating materials other than recycling paper
- The insert is easily placed in the Waste Bin
- Easy to clean
- Package contains 6 pcs.
- Fits 2010 + 2040

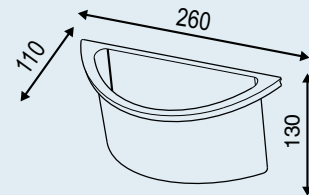

2080 TWIN METAL Waste Bin 20 L

- Colours: 2080-1 Black
2080-2 White
2080-8 Silver
- Capacity: 20 L
Size: 365 mm
Dia: 300 mm

- Package contains 6 pcs.
- Elegant in metal colours
- Strong and stable

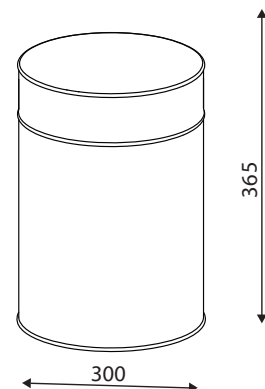

2000 TWIN HIT® Waste Bin



Colours: 2000-1 Black

Capacity: 15 L

L: 290 mm,
D: 310 mm,
H: 290/390 mm

- Package contains 6 pcs.
- TWIN HIT® is angled - so it is easy to hit
- TWIN HIT® has a bag holder - so the bag stays in place
- TWIN HIT® it is easy to change the bag - and more hygienic for the cleaners

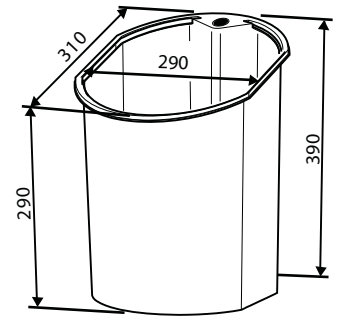

2050 TWIN HIT® Indsats/ Waste Separator



Colour: 2050-1 Black
Height: 130 mm

- Insert for separating materials other than recycling paper
- The insert is easily placed in the Waste Bin
- Easy to clean
- Package contains 6 pcs.
- Fits 2000 TWIN HIT®

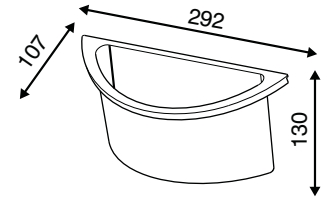

2090 TWIN METAL Umbrella Stand



Colour: 2090-8 Silver
Capacity: 28,5 L
Height: 590 mm
Dia: 270 mm

- Metal umbrella stand with decorative perforation
- With epoxy polyester coating and rubbering

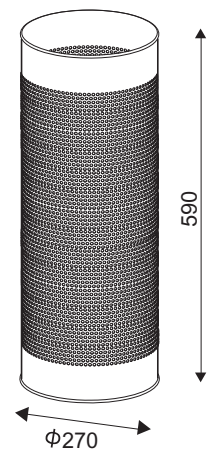

2025 / 2026 / 2027 TWIN Artistic Umbrella Holder



Size: 150x150x430 mm;
Material: Powder coating steel;
Colours: Black / White

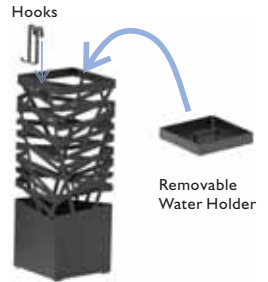

2025-1

2025-2

2026-1

2026-2

2027-1

2027-2

2028 TWIN Umbrella Holder

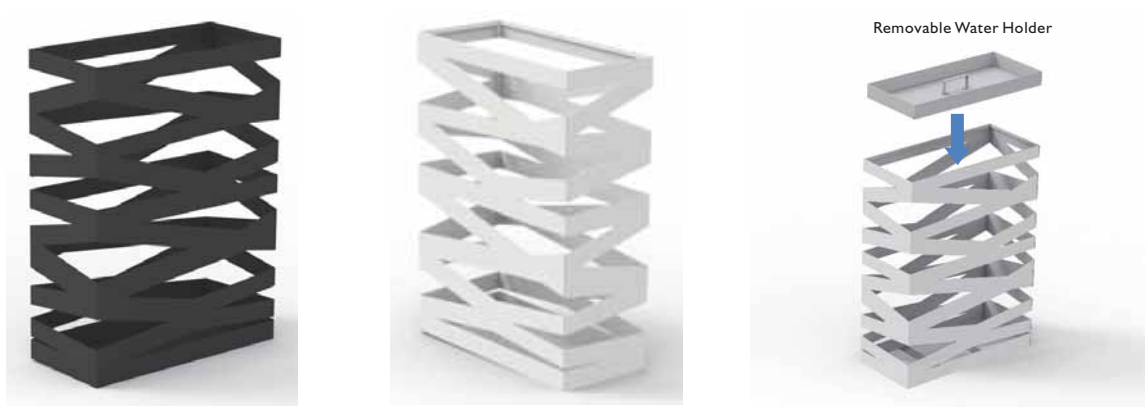

Removable Water Holder

Length: 330 mm;
Width: 150 mm;
Height: 450 mm;
Material: Powder coating steel;
Colours: Black / White

2028-1

2028-2

TWIN Fire Self-Extinguishing Wastebin



Colours: 2020-1 Black
2020-2 White
2020-8 Silver

2021-1 Black
2021-2 White
2021-8 Silver

2022-1 Black
2022-2 White
2022-8 Silver

NO.	1	2	3
Model NO.	2020	2021	2022
Volume (L)	15	20	30
Diameter x Height	260 x 350	260 x 430	300 x 510
Opening	110	110	110

- Y Round waste basket with fire-extinguishing lid for preventive fire protection;
- Y Self-extinguishing lid cuts off the oxygen supply and thus quenches the flames;
- Y Comply with TUV/GS standard;
- Y Made from steel with a scratch-proof, epoxy resin coating.

Suggestion Box / Belt Barrier systems

5211 TWIN STEEL Letter Box /Suggestion Box

- Durable, black powder coat finish;
- Optional customized front panel sticker and suggestion cards;
- Wall mounting hardware included.



5211-I

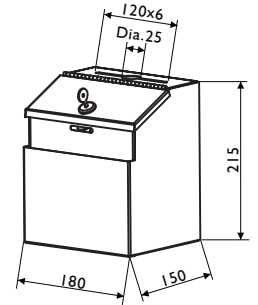

3200 TWIN Belt Barrier systems



3200-1



3200-3



3200-4

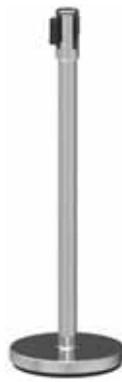

3200-13 Glittering Chrome



- Belt posts with pull-out tape belt;
- Robust post system with braked retraction;
- Powder coated or glittering Chromed metal post and base cover;
- Maximum belt extension length 2000mm; Belt width 50mm;
- Heavy cast iron base with anti-slip rubber pads on the bottom;
- 4-way system;
- Various colours' belts available.



3202 3203 TWIN Belt Barrier systems-Sign holder



3202-1



3202-13



3203-1



3203-13

- A4 format, portrait(3202) or landscape (3203);
- Chromed Plated or powder coated metal frame;
- Double sided acrylic plates;
- Suitable for TWIN belt barrier systems.





5809 Business Card Box
Colour: 5809-7 Clear Acrylic

5810 Business Card L-Stand
Colour: 5810-7 Clear Acrylic

5811 Acrylic Display A6, T-Stand
Colour: 5811-7 Clear Acrylic

5812 Acrylic Display E65
Colour: 5812-7 Clear Acrylic
Wall/table model

5815 Acrylic Display A5, L-Stand
Colour: 5815-7 Clear Acrylic

5816 Acrylic Display A5, T-Stand
Colour: 5816-7 Clear Acrylic

5820 Acrylic Display A4
Colour: 5820-7 Clear Acrylic
Wall/table model

5821 Acrylic Display A4, L-Stand
Colour: 5821-7 Clear Acrylic

5822 Acrylic Display A4, T-Stand V
Colour: 5822-7 Clear Acrylic

5823 Acrylic Display A4, T-Stand H
Colour: 5823-7 Clear Acrylic

5830 Acrylic Display A4, 3 Comp.
Colour: 5830-7 Clear Acrylic
Wall/table model

5831 Wall model A4, V
Colour: 5831-7 Clear Acrylic

5832 Wall model A4, H
Colour: 5832-7 Clear Acrylic

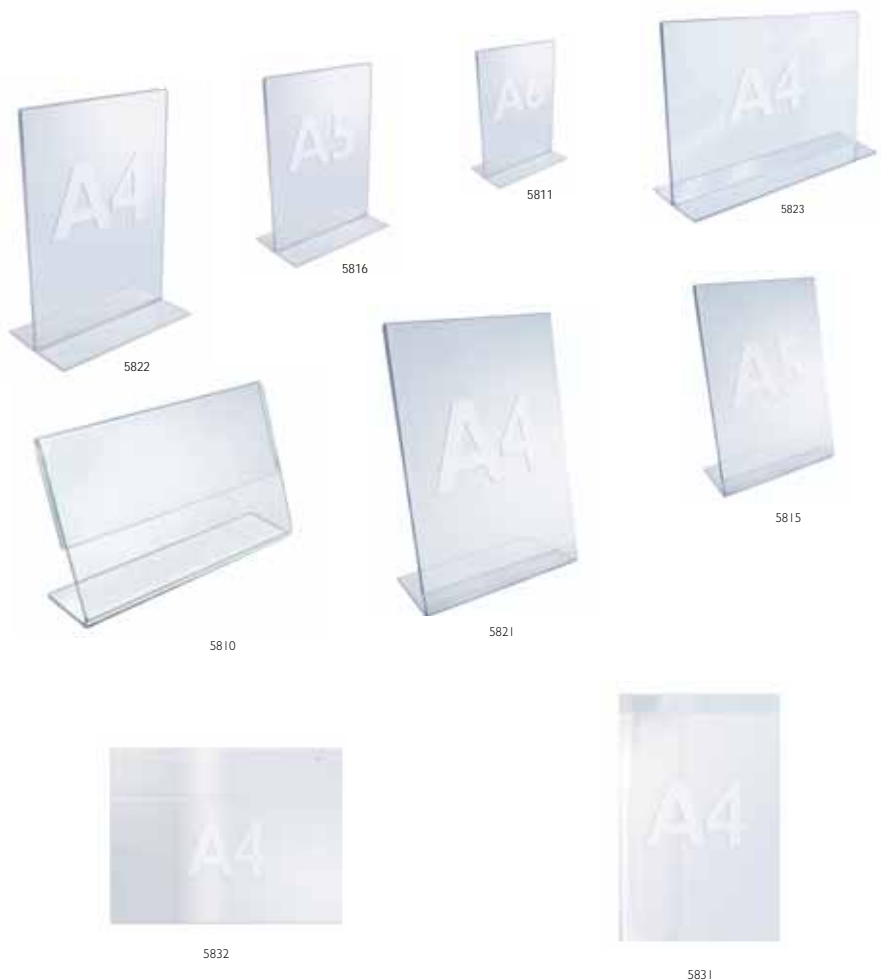

5826 TWIN Acrylic Brochures Rack/Acrylbroschüren Rack



- Wall-mounted Brochures display holder;
- Clear Acrylic; Thickness 4mm;
- Height: 325 mm, Width: 250 mm, Depth: 60 mm;
- Screw kits included.



Printer Stand/ Druckerstand
Workstations/ Terminaltische
Multi-Purpose Table/Multitisch
Multi-Purpose Cabinet/ Plastic Cabinet/ Multischrank
Copyholder /Konzepthalter

6667 TWIN CLICK Printer Shelf

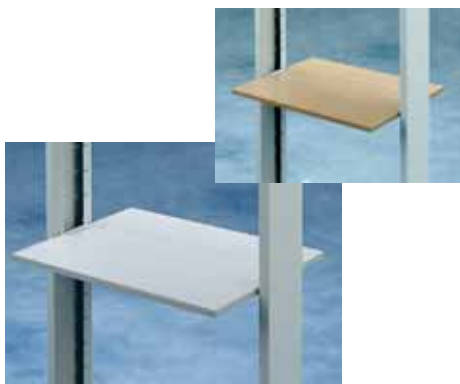

Colours: 6667-0 Beech
6667-9 Grey

- Printer Shelf in beech or grey.
- Adjustable in depth.

6751 TWIN CLICK Multi-Purpose Cabinet 2



Colours: 6751-0 Beech
6751-9 Grey
Castors: 4 (2 lockable)
Supplied complete with: 2 adjustable shelves
Mad load: 40 kg.

- Can also be used as stand for photocopier, printer, fax etc.
- Knock down, with assembly instruction and screws

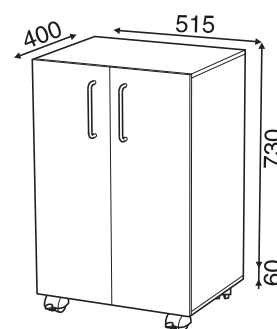

7700 TWIN LINE BASE 2 Copyholder



Colour: 7700-8 Silver

- With magnet ruler
- For adjustable distance and angle
- Strong and stable, will carry a ring binder
- Can also be used as a laptop holder

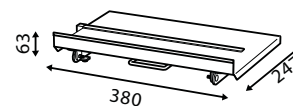
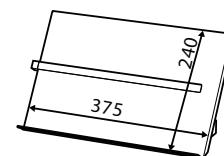

7600 TWIN LINE BASE I Copyholder



Colour: 7600-8 Silver

- With magnet ruler
- For adjustable distance and angle
- Strong and stable, will carry a ring binder
- When not in use, the plate is in the base
- The plate slides easily on ball bearing slides
- Can also be used as a laptop stand

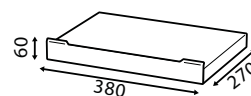
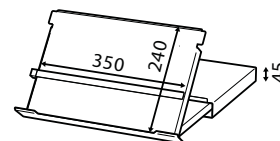

7400 Acrylic Copyholder

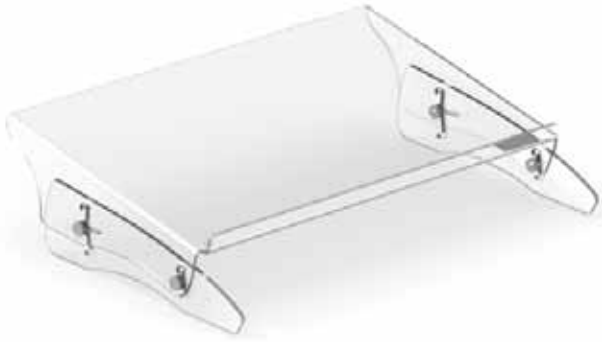

7_options for height and angle adjustment

Adjustable Angle: 7°, 20°, 30°

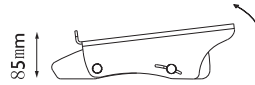

Adjustable Angle: 13°, 23°

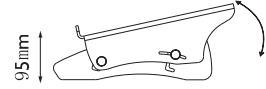

Adjustable Angle: 7°, 17°

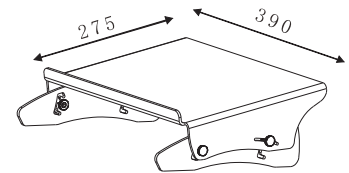
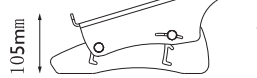

7500 Acrylic Copyholder



7_options for height and angle adjustment

Adjustable Angle: 7°, 18°, 26°

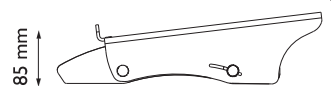

Adjustable Angle: 12°, 21°

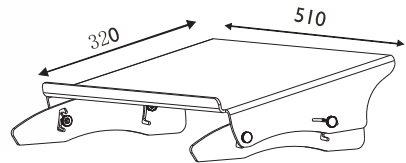

Adjustable Angle: 7°, 16°



- Made of high quality transparent acrylic; Easy to make an ergonomic correct positioning;
- Three preset heights plus different angle settings; Easy height and angle adjustment;
- Heavy duty enough to accommodate books or laptops; Max. load capacity: 10Kg; Elegant and Durable;

6880 TWIN Portable Lap Desk, Flexible Seating



- All-in-one plastic desk;
- Flexible Seating;
- Indoors or outdoors use;
- Durable plastic seat is lightweight and easy to carry.

7310 Adjustable Aluminum Laptop Stand



- Material: High-quality Aluminum Alloy;
- Wide Compatibility: compatible with all laptops for 10-17 inch;
- Easy Adjustable, Foldable & Portable Design;
- With rubber anti-slipery pads, stable when using.
- With heat emission holes;
- Size: 270x228x50 (Folding) ; 270x215x300mm(Unfolding).
- Loading capacity: 10Kg;



7311 Adjustable Aluminum Laptop Stand



- Material: High-quality Aluminum Alloy;
- Easy Adjustable, Foldable & Portable Design;
- With rubber anti-slipery pads, stable when using;
- Width: 190mm; Max. Height: 130mm;
- Loading capacity: 6Kg;



1281 / 1282 / 1283 / 1284 / 1285 Bookend



1281-1

Length: 150 mm;
Height: 210 mm;
Width: 115 mm;
Material: Powder coated sheet steel;



1282-1



1283-1



1284-1



1285-1

Colours: Black:
1281-1 / 1282-1 / 1283-1 / 1284-1 / 1285-1
White:
1281-2 / 1282-2 / 1283-2 / 1284-2 / 1285-2

1291 Door Stopper



Length: 120 mm;
Height: 36 mm;
Width: 45 mm;
Material: Rubber;
Colour: Black



6720

6 tiers, 2 columns
6 Etagen, 2 Spalten

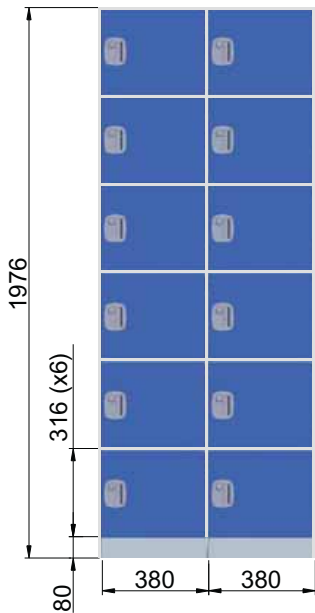
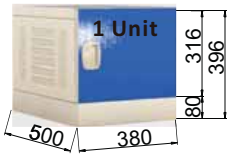

6721

4 tiers, 2 columns
4 Etagen, 2 Spalten

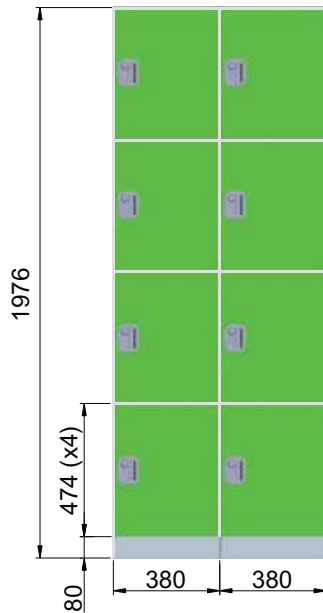

6722

3 tiers, 2 columns
3 Etagen, 2 Spalten

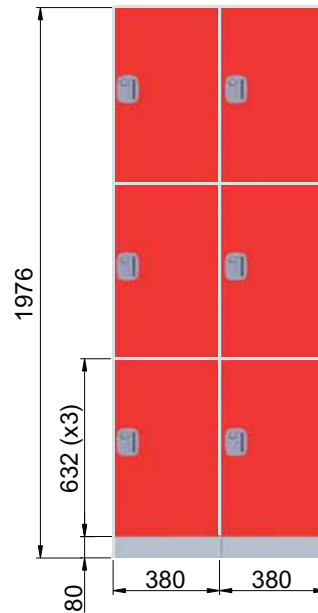

6723

2 tiers, 2 columns
2 Etagen, 2 Spalten

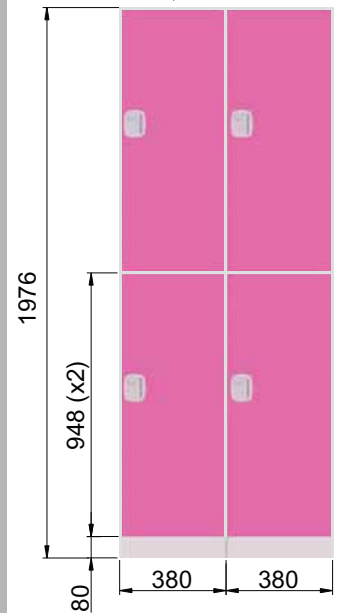

Door color code

- 1** Black Ral 9005
- 2** White Ral 9010
- 3** Yellow Ral 1003
- 4** Red Ral 3028
- 5** Blue Ral 5015
- 6** Orange Ral 2004
- 7** Anthracite RAL 7024
- 9** Grey Ral 7035
- 10** Green Ral 6018
- 15** Light Blue
- 16** Wood Grain 1
- 17** Wood Grain 2
- 18** Violett
- Body boards Grey Ral 7035

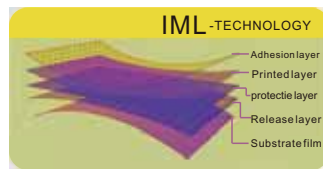

Water-proof/Wasserdicht



UV resistance: Anti-aging; Anti-scratch

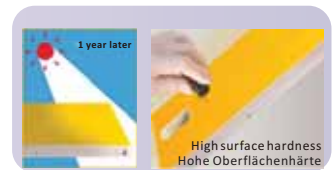

Easy to install and disassemble without any tool



Different high quality Locks



Ventholes: Insects prevention



KD design; Flat packing; Easy to assemble



Combine as you wish; Lock firmly

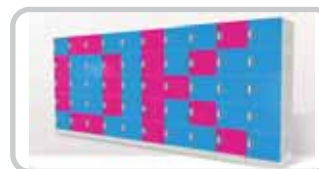

High-strength Nylon hinge



Cable Cage

TWIN LINE Cable Pipes/ Kabelkanäle

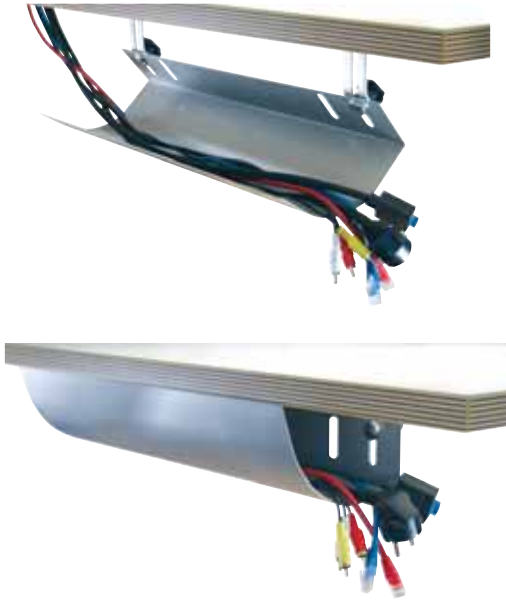

- Protects cables and users
- A crossbar is no problem
- With screws and assembly instruction

Colour: Silver

I270

W:460 mm D:185 mm H:100 mm

I271

W:760 mm D:185 mm H:100 mm

I272

W:1160 mm D:185 mm H:100 mm

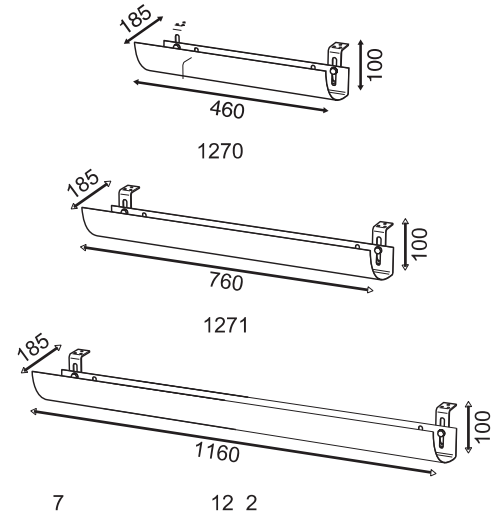

I273 TWIN LINE Length Adjustable Cable Pipes/Längenverstellbare Kabelkanäle

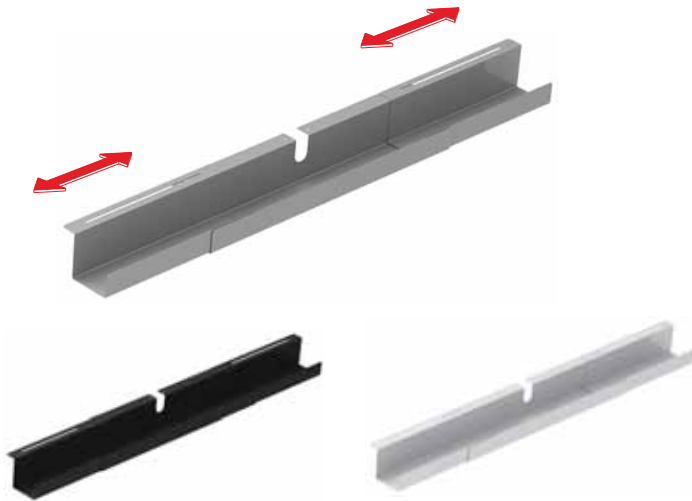

Colours: I273-1 Black
I273-2 White
I273-8 Silver

- Power coated steel in silver;
- Length adjustable : 790-1500 mm, Height: 120 mm, Depth: 115 mm;
- Screw kits included .

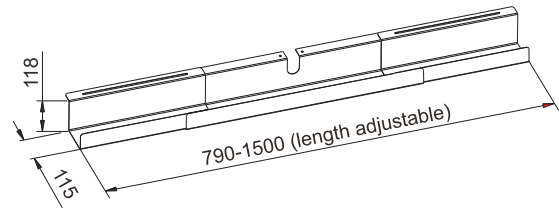

I274 TWIN LINE Length Adjustable Cable Pipes/Längenverstellbare Kabelkanäle



- Crafted with Power coated steel for durability;
- Easy & convenient - the tray can be open towards the user or towards the back of the desk;
- Length adjustable;
- Black, Silver and white colors available.

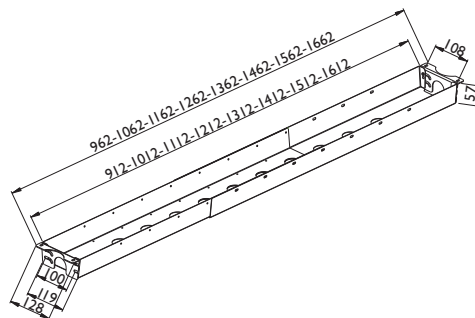

I4197 TWIN Kabeltrådkurv/ Cable Cage



I4197-8

Colour: I4197-8 Silver
 L: 490 mm
 T: 100 mm H: 50 mm

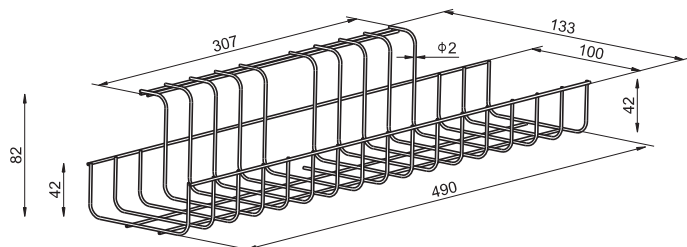

I4198 TWIN Kabeltrådkurv/ Cable Cage



I4198-8

Colour: I4198-8 Silver
 L: 790 mm
 T: 100 mm
 H: 50 mm

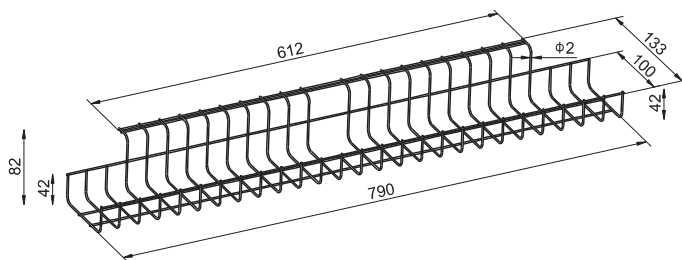

I4199 TWIN Kabeltrådkurv/ Cable Cage

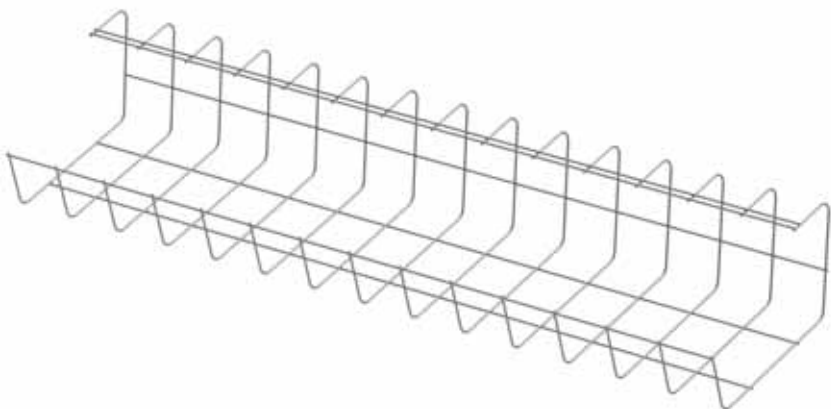

Colour: I4199-8 Silver
 L: 790 mm
 T: 185 mm
 H: 105 mm

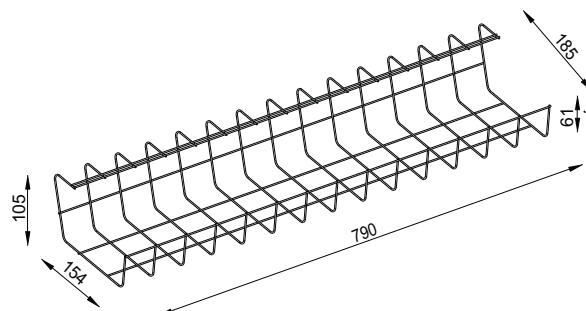

6512 TWIN CPU Mobile



Colour: 6512-9 Grey
 Castors: 4 (2 lockable)

- Mobile on castors- a CPU can be heavy
- Raised above the floor to avoid dust being drawn into the CPU, easy to clean
- Adjustable in width
- Mounting instruction included
- Can be assembled horizontal or angled
- Max. load: 30 Kg.

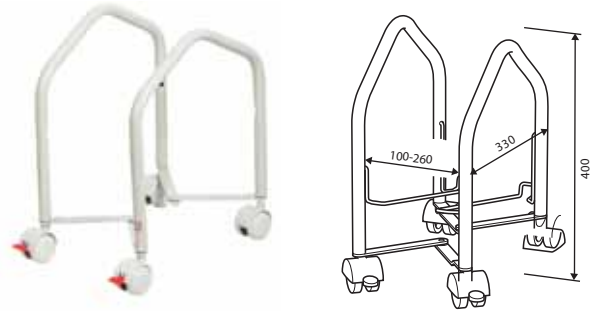

1202 TWIN LINE CPU Holder/ CPU Halter



Colours: 1202-1 Black
 1202-2 White
 1202-8 Silver
 1202-9 Grey

- Mounting:
 Max. load: 30 kg.
- Attaches to underside of table top
 - Table top min. 20 mm
 - Screws and assembly instructions enclosed
 - Optimal for adjustable tables

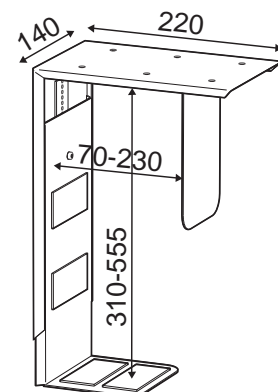



2100 TWIN PANORAMA Letter Tray System

Colours: 2100-1 Black
2100-2 White
2100-5 Blue
2100-9 Grey

Format: C4

Packed: 4 letter trays
1 Top board
4 Shields
10 Inserts

- Easy clicked together
- Can be mounted on the wall

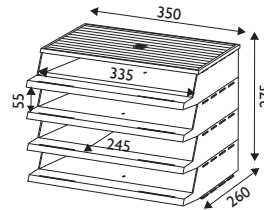

2500 TWIN FLEX Letter Tray System



Colours: 2500-1-1 Black/Black
2500-1-4 Black/Red
2500-1-5 Black/Blue
2500-9-9 Grey/Grey

Format: C4

Packed: 4 letter trays
1 Top board
4 Shields
10 Inserts

- Easy clicked together
- with two possibilities as deep or wide

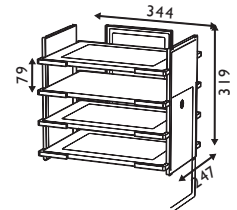
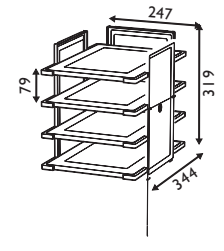

2200 TWIN Flexible Wall-mount Literature Holder



2200-1



2200-2



2200-7



2600-9

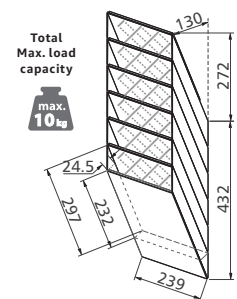

Total Max. load capacity
max. 10kg

Colours:

2200-1
Black
Ral 9005

2200-2
White
Ral 9016

2200-7
Transparent

2200-9
Light Grey
Ral 7012

For documents up to A4 size of portrait orientation;
Easy clicked together; Compact packaging;
Extendable to 12 or more compartments of different format;
Immediate identification of documents via its transparent compartments (2200-7);
6 compartments; Mountings kits included;
Made by high quality plastic; Sturdy and durable.



Under Desk Organizer

9040 TWIN Svingbar Pennebakke/Pen Tray - rotatable



Colours: 9040-1 Black
9040-2 White
9040-9 Grey

- Suitable for most table tops with limited space
- Rotation: 360 degrees
- The TWIN Pen Tray is a good solution, where order and workspace is required
- Easy to fit under the table
- Mounts with two screws
- Refined quality and beautiful design

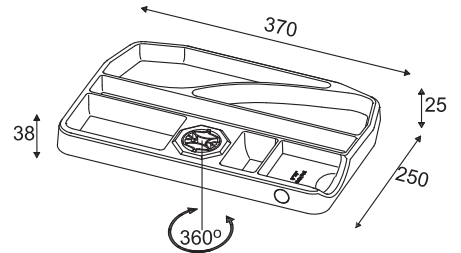

9041 Rotating Under Desk Organizer



- 9040 Pen Tray with sturdy c-clamp;
- Sturdy c-clamps - attach to the workstation without causing any damage to your desk. It hold everything tightly in place and are easily adjustable for user convenience; Easy installation;
- 360° Rotating Under Desk Organizer - you can easily open or hide it according to your needs. It can be fixed back in place easily. Capacity Large and Multi-space Design.



9041-9



9041-1

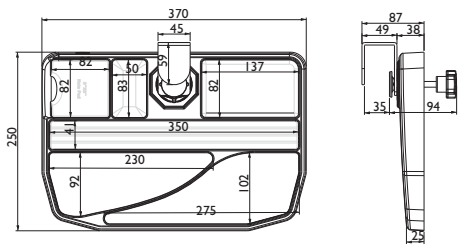

9030 TWIN Under Desk Drawer



9030-1



9030-2



- Mounted Sliding Under Desk Pull-Out Drawer;
- Product size: 420x410x100 mm;
- High quality powder coated steel;
- 2 PCS durable 3-fold slide; Heavy duty and soft close sliding track;
- Easy to be installed under the desktop with screws; Screws kit included;
- Keeping your desktop neat and clean;
- Various models with different locks are available.

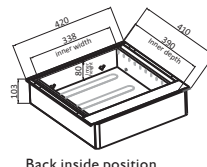

Back inside position

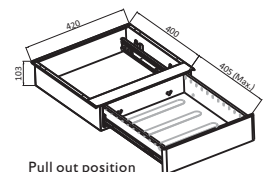

Pull out position

9070 TWIN Ergonomic Keyboard Drawer



- Under desk MDF wood shelf;
- Smooth sliding mechanism: equipped with steel ball-bearing glide tracks, the keyboard drawer easily slides in and out for convenient use.;
- Height adjustable keyboard tray;
- Sturdy c-clamps - attach to the workstation without causing any damage to your desk with sturdy c-clamps that hold everything tightly in place and are easily adjustable for user convenience; Easy installation;
- 360° Rotating Under Desk Organizer - you can easily open or hide it according to your needs. It can be fixed back in place easily. Capacity Large and Multi-space Design.

360° Rotating Under Desk Organizer

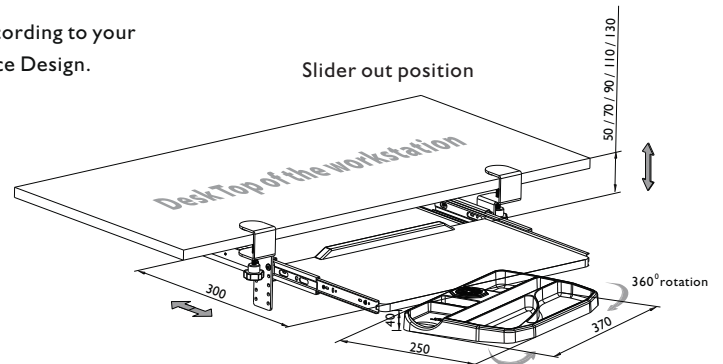
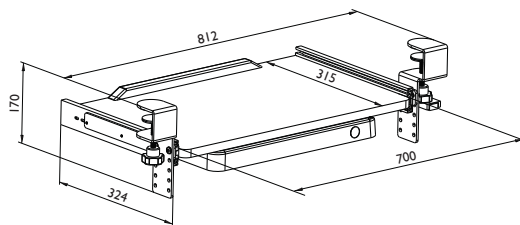

9060 TWIN Keyboard Drawer



- Colour: 9060-I Black
- Height under desk plate can be adjusted from 20 to 50 mm
- Pencil tray in wrist support
- Assembling instruction enclosed

B: 550 T: 370 H: max. 35

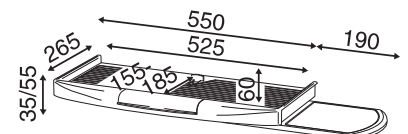
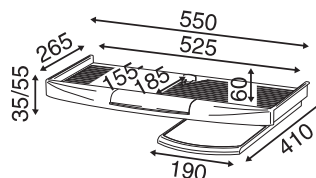

Sack Truck/ Sackkarre Platform Trolley/R ollwagen



9500-8 TWIN sammenklappelig Sack Truck - Foldable/Sackkarre - Klappbar

Colour: 9500-8 Silver/Black

- Compact when folded - quick to unfold
- Folds extremely flat by a simple press on the button.
- Minimum storage space required
- Rubberband included

Measures HxWxD
Unfolded: 985x390x380 mm
Folded: 700x390x55 mm
Load capacity: 80 kg.

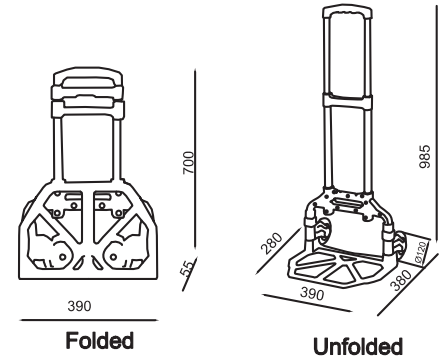

9530 TWIN Stair Climbing Cart



- **Strong Load-bearing:** Our stair climbing hand truck is made of steel frame, which has a greater load-bearing capacity, sturdy and durable for long-term use.
- **Upgraded TPR Soundproof 3-wheel:** Silent wheels provide smooth and quiet rolling for the portable trolley, easy to go up and down stairs, non-slip and wear-resistant, suitable for all surfaces such as grass, cobblestone roads, concrete roads, gravel roads, etc.
- **Collapsible and Portable:** This foldable shopping cart one second open and close, saving more space, easy to carry and transport.

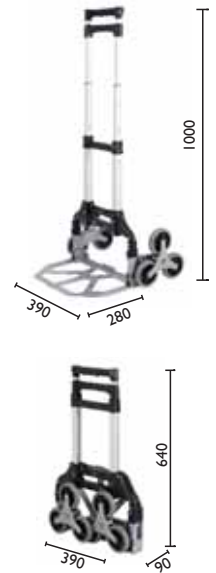

9710/9720 TWIN Platform Trolley - Foldable



9710

- High handle aluminium foldaway trolley
- Compact when folded - easy to unfold
- Non slip vinyl deck to protect goods
- Buffer all around the deck to protect your walls

Colour: 9710-2 white/blue
Max load: 150 kg

9720

Colour: 9720-2 white/blue
Max load: 300 kg

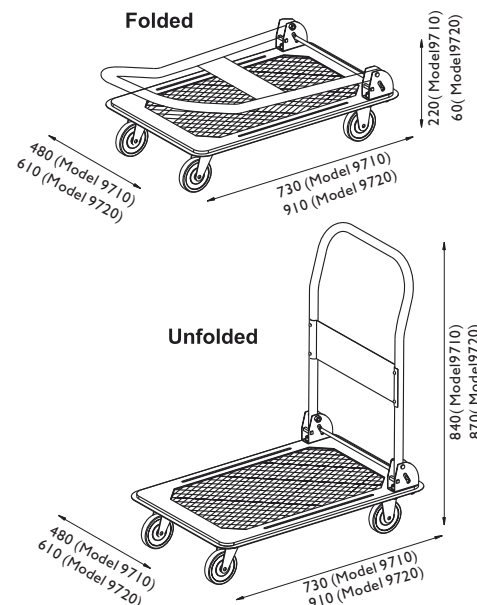

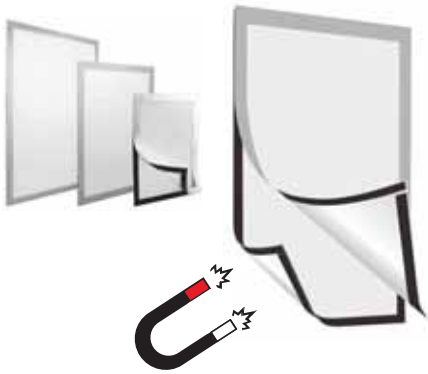

7151, 7152, 7153 TWIN Magnetic Frame

Model	7151	7152	7153
Size	A5	A4	A3

- Display Frame with fold-able magnetic;
- Transparent and Glare-free front side;
- Quick insertion and easy changing of documents;
- Magnet backing. Self adhesive on the surface of iron;
- Can be used horizontally or vertically;
- Various colours of frames available.



7161, 7162, 7163 TWIN Magnetic Frame

Model	7161	7162	7163
Size	A5	A4	A3

- Self-adhesive Poster Frames;
- large-scale advertisement;
- Transparent, Low reflection, UV stabilised special Film;
- Frames open easily due to magnet;
- The frames is simply fitted to the inside of a shop window;
- Allowing poster to be read from outside while keeping it protected behind the glass.
- Various colours of frames available.

7212, 7213, 7214 TWIN Magnetic Document Panel

Model	7212	7213	7214
Size	A5	A4	A3



- Magnetic rubber backing;
- Wall mounted;
- Anti-glare clear PVC for easy viewing of contents;
- Quick insert wallet.

1768 TWIN Strong Magnet Hook

Model	Capacity (Kg.)	Size (mm)
1768	1.5	Dia50, Depth 25

- Stainless Hook;
- Various colours available.



1766 TWIN Smart Magnet Storage Box

Model	Capacity (Kg.)	Size (mm)
1766	1.0	Length 128, Depth 40, Height 76



1765 TWIN Magnet Eraser with Holder

- Magnet Eraser which can also holds the marker Pen;
- Felt Pad;
- Cost effective.
- Size: Length 144, Depth 26, Height 52mm





8156 TWIN Elegant Coat Stand

- Concrete base with black plastic coating;
- Dia. 355mm black plastic base cover;
- Base can be as umbrella holder;
- Power coated steel tube in silver - Dia. 38mm;
- Solid wood ball in beech color.



8120 TWIN Elegant Coat Stand

- Rotatable black plastic hook base;
- Sturdy plastic hooks in black;
- Strong powder coated metal tube in black, Dia. 38 mm;
- Size: 350x350x1750 mm.



8154 TWIN Upright Coat Stand

- Concrete base with black plastic coating;
- Dia. 355mm black plastic base cover;
- Base can be as umbrella holder;
- Power coated steel tube in silver - Dia. 48mm;
- Solid wood ball in beech color.



8131 TWIN Crown Coat Stand

- Rotatable black metal hook base;
- Sturdy plastic hooks in black;
- Strong powder coated metal tube in black, Dia. 48 mm;
- Size: 430x430x1760 mm.



8117 TWIN Smart Coat Stand

- Powder coated metal cross bar base;
- Metal tube with powder coating in silver;
- Metal hook with powder coating in silver;
- Solid wood caps in beech on hooks' end;
- Size: 500x500x1700



8118 TWIN Coat Stand

- Powder coated metal cross bar base;
- Metal tube with powder coating in silver;
- Rotatable black plastic hook base;
- Sturdy plastic hooks in black;
- Size: 500x500x1750 mm.



8158



8159

8158 / 8159 TWIN Classic Coat Stand

- Rotatable plastic hook base;
- Sturdy metal hooks in silver; 8158: powder coated, 8159: chrome plated;
- 8158: Solid wood caps in beech on hooks' end;
- 8159: Black plastic caps on hooks' end.
- 8158: Strong powder coated metal tube in silver, Dia. 38 mm;
- 8159: Glossy chrome plated tube, Dia. 38 mm;
- Size: 405x405x1790 mm.



855 TWIN Coat Stand

- Silver painted metal tube. Marble Base
- Solid Wooden caps
- Dia. 380mm, Height 1870mm



863 TWIN Coat Stand

- Silver painted metal tube. Marble Base
- Solid Wooden caps
- Dia. 380mm, Height 1890mm



8133 TWIN Multi-functional Coat Stand

- Heavy concrete base for excellent stability ;
- Dia. 355mm black plastic base cover ;
- Umbrella holder with integrated drip tray on the base;
- Durable powder coated steel tube, Dia. 38 mm;
- 6 black plastic coat hanger included;
- Size: 500x355x1730 mm.



8157 TWIN Multi-functional Coat Stand

- Heavy concrete base for excellent stability ;
- Dia. 355mm black plastic base cover ;
- Umbrella holder with integrated drip tray on the base;
- Durable powder coated steel tube, Dia. 38 mm;
- With 6 high quality powder coated steel coat hangers;
- Solid wooden caps in beech color on the end of hooks;
- Size: 465x405x1750 mm.



8163 TWIN Multi-functional Coat Rack

- Sturdy steel construction, durable powder coating in silver ;
- With 6 coat/hat hooks on 2 sides;
- Mobile on 4 durable swivel castors, with wheel stops;
- With 6 high quality powder coated steel coat hangers;
- Solid wooden caps in beech color on the end of hooks and hangers;
- Size: 1140x550x1760 mm.

Coat Stand / Coat Hanger



8114 TWIN Coat Stand

- Silver painted steel structure
- Marble Base
- Solid Wooden caps
- Dia. 350mm, Height 1720mm



8181 TWIN Coat Stand

- Silver painted steel structure
- Marble Base
- Solid Wooden caps
- Dia. 350mm, Height 1720mm



856 TWIN Coat Stand

- Silver painted metal tube. Marble Base
- Solid Wooden caps
- Dia. 380mm, Height 1870mm



8273 TWIN Coat Stand

- Black painted metal tube. Marble Base
- With 4 high quality powder coated steel coat hangers;
- Dia. 380mm, Height 1720mm



8020



8021



8022

8020/ 8021/ 8022 TWIN Wall mounted Coat Hanger

- Sturdy steel construction, durable powder coating in silver;
- Solid wooden caps in beech color on the end of hooks;
- Wall mounted. mounting kits included;
- Size: 8020: 300 (L)x170 (H)x105 (D) mm;
- 8021: 450 (L)x170 (H)x105 (D) mm;
- 8022: 750 (L)x170 (H)x105 (D) mm.



8023 TWIN Hooked Coat Hanger

- Sturdy steel construction, durable powder coating in silver;
- Solid wooden caps in beech color on the end of hooks;
- Hooked on doors or partitions for easy use;
- Size: 300 (L) x 360 (H) x 140 (D).

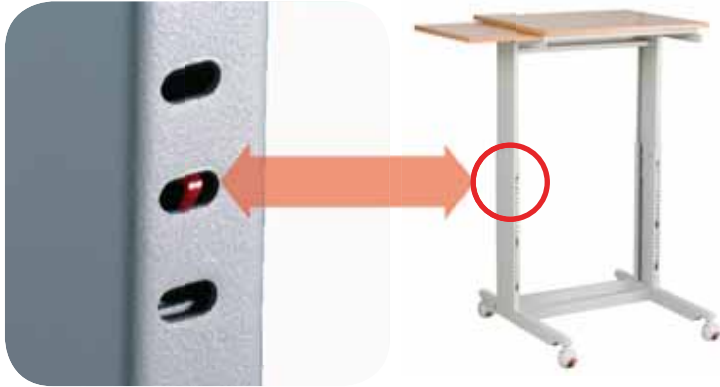

Freedom of choice - the right height for sitting, standing or any height in between.
Lift the monitor and keyboard plate and **CLICK** to the correct working height.

6830 TWIN CLICK Printer Stand I



Colours: 6860-0 Beech
6860-9 Grey
Max. load: 40 kg.
HEAVY DUTY castors:
2 with and
2 without brakes
Accessories: 6667 + 9040

- Grey frame with panels in beech or grey
- Incl. 2 printer shelves
- Provides space saving
Accommodate a printer, CPU, fax, paper trays and other devices

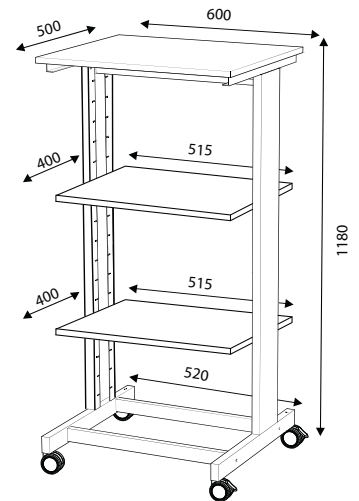

6860 TWIN CLICK Printer Stand 2



Colours: 6860-0 Beech
6860-9 Grey

Max. load: 40 kg.
HEAVY DUTY Castors:
2 with and 2 without brakes
Accessories: 6667 + 9040

- Grey frame with panels in beech or grey
- Incl. 2 printer shelves
- Provides space saving
Accommodate a printer, CPU, fax, paper trays and other devices

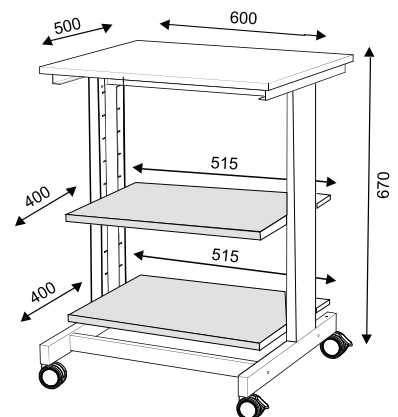

6810 TWIN CLICK Workstation

Colours: 6810-0 Beech
6810-9 Grey

Castors: 2 with brakes
and 2 without
Max. load: 40 kg.

- Desktop in beech or grey adjustable in depth
- Including printer shelf
- Lift and CLICK for adjustment

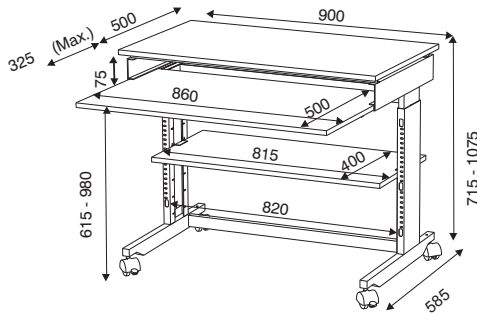

6820 TWIN CLICK Workstation

Colours: 6820-0 Beech
6820-9 Grey

Castors: 4 (2 lockable)

Accessory: 6667

- desktop in beech or grey
- Including printer shelf
- Retractable keyboard plate
- Lift and CLICK for adjustment

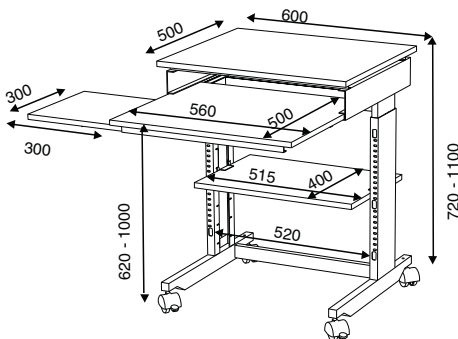

6651 TWIN CLICK Multi-Purpose Table

Colours: 6651-0 Beech
6651-9 Grey

Castors: 2 with brakes
and 2 without

W: 600 mm, D: 500 mm,
H: 660-1040 mm
Max. load: 40 kg.

- Grey frame with desktop in beech or grey
- Includes sliding shelf, sliding out to right or left
- A multi-purpose table that can be used for laser printer, fax etc.
- Accessories: 6667

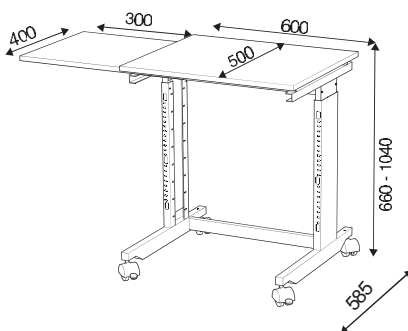

6650 TWIN MULTI-PURPOSE TABLE/MEHRZWECK-TABELLE

Colours: 6650-1 Black



- Grey powder coated steel construction;
- Black melamine coated MDF board with 2 stoppers to prevent items from slipping off;
- Height adjustable from 600-900mm in easy way; Angle adjustable quickly;
- Mobile on 4 casters. 2 casters include brakes for locking position.
- Supplied flat pack – easy self-assembly;

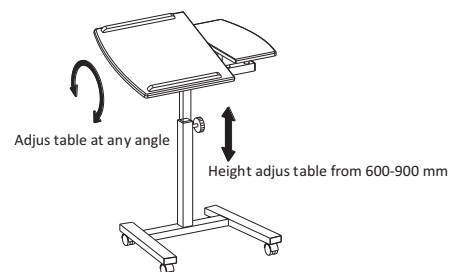
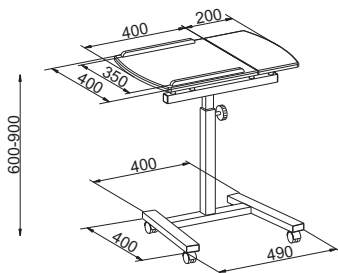

- Lightweight and durable aluminum construction, 660mm base. 1850mm height;
- Monitor mount adjusts easily for optimal viewing;
- Height adjustable for Monitor mount and Keyboard tray in easy way;
- Keyboard/Mouse tray up or down easily for storage;
- Retractable mouse tray that can be attached on either side for convenience;
- Soft Wrist Pad and Mouse pad with soft wrist foam for comfort
- Strap CPU Holder assembles CPU tightly in easy way.
- 5 silent casters. 3 casters include brakes for locking position.

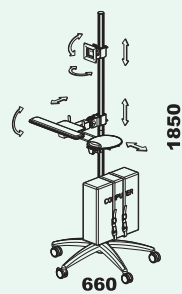

687I TWIN MOBILE LAPTOP WORKSTATION/ARBEITSPLATZ



- Lightweight and durable aluminum constructio, 660mm base. 1350mm height;
- Laptop tray fits typical laptops up to 15" screen;
- Platform is angled at 10 degrees for ergonomic operation;
- Height adjustable in easy way;
- The security bar secures your laptop via included screws or small padlock.
- Retractable mouse tray that can be attached on either side for convenience;
- 5 silent casters. 3 casters include brakes for locking position.

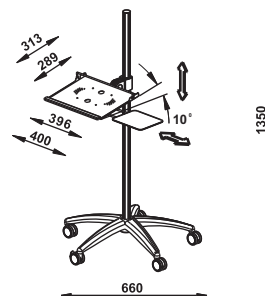

Rectangular Table / Corner Desk

6930 / 6931 / 6932 TWIN Rectangular Table



- E1 grade T15mm melamine coated chipboard, 6 colors available;
- Frame made of rectangular tubular steel 50x25 mm with powder coating;
- Table legs with floor level adjustment screws;
- Heavy duty desk; Durable and stable;
- Supplied flat pack – easy self-assembly; Mail Order Packaging.

Beech / Silver



Black / Silver



White / White



Walnut / White



Oak / White



Grey wood / White

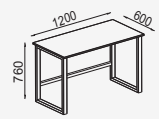
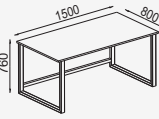
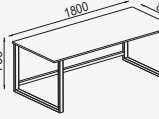

Measures	Item No.	Table Top colour	Metal Frame colour
1200 x 600 x 760 	6930-0	Beech finish	Silver
	6930-1	Black	Silver
	6930-2	White	White
	6930-16	Walnut finish	White
	6930-20	Oak finish	White
	6930-21	Grey wood finish	White
1500 x 800 x 760 	6931-0	Beech finish	Silver
	6931-1	Black	Silver
	6931-2	White	White
	6931-16	Walnut finish	White
	6931-20	Oak finish	White
	6931-21	Grey wood finish	White
1800 x 800 x 760 	6932-0	Beech finish	Silver
	6932-1	Black	Silver
	6932-2	White	White
	6932-16	Walnut finish	White
	6932-20	Oak finish	White
	6932-21	Grey wood finish	White

6935 / 6936 TWIN Corner Desk



- E1 grade T15mm melamine coated chipboard, 5 colors available;
- Frame made of rectangular tubular steel 50x25 mm with powder coating;
- Table legs with floor level adjustment screws;
- Mountable on both sides;
- Heavy duty desk; Robust and stable;
- Supplied flat pack – easy self-assembly; Mail Order Packaging.

Beech / Silver



Black / Silver



White / White



Walnut / White



Oak / White



Grey wood / White

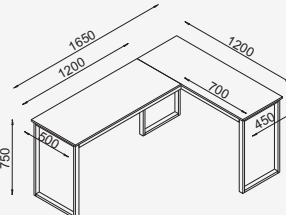
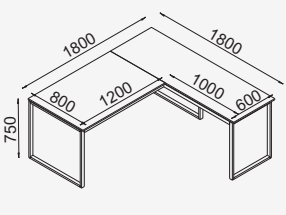

Measures	Item no.	Desktop colour	Metal Frame colour
1650 x 1200 x 760 	6935-0	Beech finish	Silver
	6935-1	Black	Silver
	6935-2	White	White
	6935-16	Walnut finish	White
	6935-20	Oak finish	White
	6935-21	Grey wood finish	White
1800 x 1800 x 760 	6936-0	Beech finish	Silver
	6936-1	Black	Silver
	6936-2	White	White
	6936-16	Walnut finish	White
	6936-20	Oak finish	White
	6936-21	Grey wood finish	White



6653 TWIN Movable Lifting Table

- Height range: 765-1065mm
- Max. loading: 60kgs
- Stationary holder: optional
- Top: MDF+PVC, 715x475x18mm w/ curve
- Frame: Alu. die-casting, powder coated Base: Alu. die-casting, powder coated.
- Castors: 2.5"PU castors, 2 lockable.

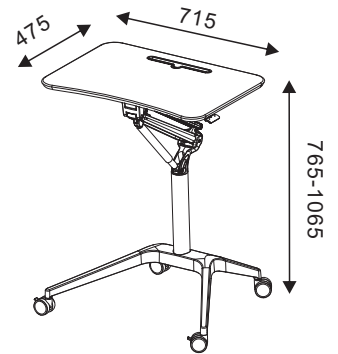

6665 TWIN Movable Lifting Side Table

- Height range: 680-1080mm
- Max. loading: 60kgs
- Top: MDF+PVC, 900x420x18mm rectangle
- Column: Alu. die-casting, powder coated
- Base: Metal, powder coated
- Castors: 2.5"PU castors, 2 lockable.
- Box size: 1150x650x200mm
- G.W.: 16.00 kgs

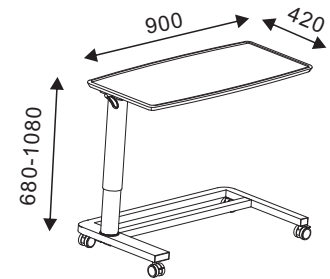

6660 TWIN Gas Lifting Side Table

- Gas spring lifting mechanism; Height adjustable;
- E1 grade T18 mm melamine coated chipboard. Various colors available;
- Alu. die-casting construction;
- Powder coating in silver color;
- Extra holder for ipad, cell phone, pens etc.

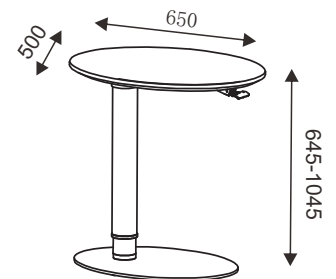

Color options

Color code of wood board



XXXX-1
Black



XXXX-2
White



XXXX-22
Marple Wood



XXXX-16
Walnut

Color of metal frame



White



Silver



Black

6655 TWIN Ergonomic Laptop desk



- High-quality gas spring lifting mechanism;
- Soft and smooth height adjustments by pressing the handler easily;
- Durable and robust powder coated steel structure make the desk very stable;
- E1 grade melamine coated chipboard in black color;
- Desktop slot provides extra space for cell phone and pens etc.
- Ergonomic keyboard tray keeps proper height between keyboard and monitor to prevent wrist strain.

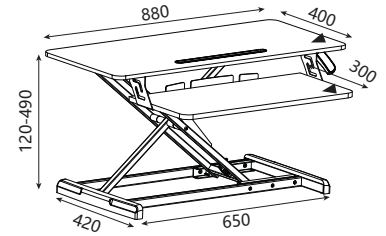

6656 TWIN Bamboo Portable Desk



- High-quality bamboo desk top;
- Soft pillow on the backside;
- Pillow cover: nylon fabric; Pillow core: polystyrene foam;
- Desktop slot provides extra space for cell phone, ipad and cup etc.
- Multi-used as a laptop desk, copy holder or a pillow for rest;
- Provides more comfort and more stability;
- This laptop desk is lightweight, that allows you to easily take it with you everywhere.

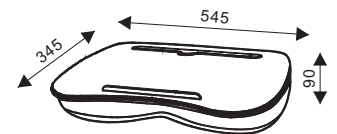

6657 TWIN Bamboo Portable Desk



- High-quality bamboo desk top;
- Soft pads on the backside;
- Soft pad cover: nylon fabric; Pillow core: polystyrene foam;
- Desktop slot provides extra space for cell phone, ipad etc;
- Desktop with soft wrist foam for comfort use;
- with mouse pad for convinient use;
- Multi-used as a laptop desk, copy holder or a pillow for rest;
- This laptop desk is very lightweight and comes with a handle, that allows you to easily take it with you everywhere.

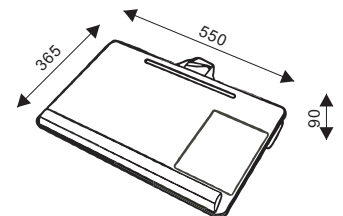

6753 / 6754 TWIN Portable Folding Table



- ;HDPE plastic table top;
- Thanks to the folding function, the desk can be set up in a simple way and can be folded up again when not in use and stowed away to save space;
- This desk can be folded in small size and comes with a handle, that allows you to easily take it with you everywhere;
- The sturdy powder coated metal frame with locking mechanism offers optimum stability at all times;
- Compactfolded size / weight:

6753: 7 x 90 x 74 cm, 11 kg;

6754: 7 x 76 x 70 cm, 10 kg.

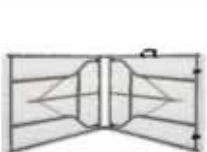
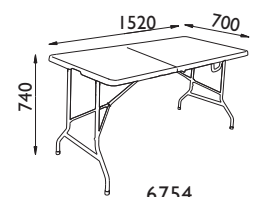
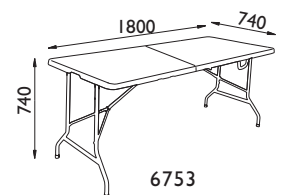

Folded view

6920 / 6921 / 6922 / 6923 TWIN Acoustic Partition

- 2 sided acoustic polyester fiber felts absorbs sound in open spaces;
- Each felt panel thickness 10mm. Sound absorbency rating of 0.85 NRC (85%);
- The inner frames of the office dividers are made of wooden board, which is strong and durable;
- Strong bearing capacity on the metal feet, which is not easy to tilt;
- The covering polyester fabric is scratch-proof and wear-resistant, lasting long service time;
- 2 sided pin board. For pinning up photos and documents; panel meets UL94-HB flame resistance standards.



6920-1



6921-5



6922-9



6923-3

Foot provided separately



69201
fix foot with floor
level adjustment screws



69202
Mobile foot



69203
Corner foot

Measurements

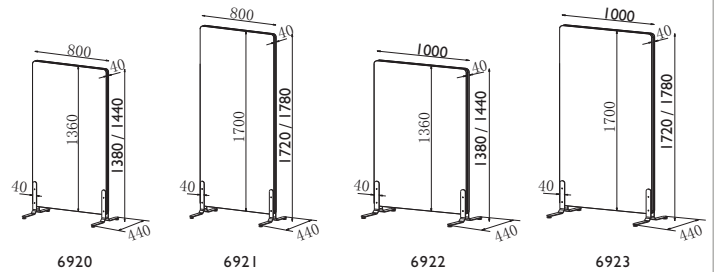

Four Standard Colors:

- 6920-1 / 6921-1 / 6922-1 / 6923-1: Dark grey
- 6920-3 / 6921-3 / 6922-3 / 6923-3: Brown
- 6920-5 / 6921-5 / 6922-5 / 6923-5: Blue
- 6920-9 / 6921-9 / 6922-9 / 6923-9: Light Grey

Various colors fabric available.



TWIN Table Acoustic Partition

Technical features

- ▶ 2 sided acoustic polyester fiber felts absorbs sound in open spaces;
- ▶ Each felt panel thickness 10mm. Sound absorbency rating of 0.85 NRC (85%);
- ▶ The inner frames of the office dividers are made of wooden board, which is strong and durable;
- ▶ Strong bearing capacity on the metal clamps, which is not easy to tilt;
- ▶ The covering polyester fabric is scratch-proof and wear-resistant, lasting long service time;
- ▶ 2 sided pin board. For pinning up photos and documents; panel meets UL94-HB flame resistance standards.



Light Grey



Dark grey

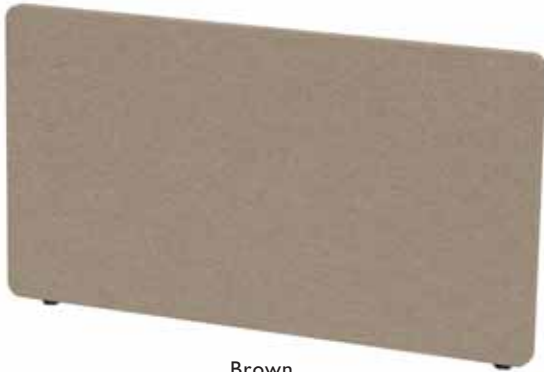

Brown



Blue

Various colors fabric available.



Measurements

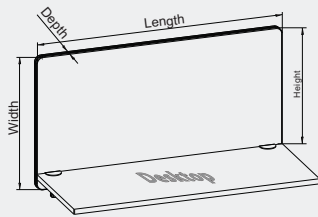

Model No.	Partition Size LengthxWidthxDepth	Height	Model No.	Partition Size LengthxWidthxDepth	Height
6940	600x600x32 mm	500	6950	600x650x32 mm	570
6941	800x600x32 mm	500	6951	800x650x32 mm	570
6942	1000x600x32 mm	500	6952	1000x650x32 mm	570
6943	1200x600x32 mm	500	6953	1200x650x32 mm	570
6944	1400x600x32 mm	500	6954	1400x650x32 mm	570
6945	1600x600x32 mm	500	6955	1600x650x32 mm	570
6946	1800x600x32 mm	500	6956	1800x650x32 mm	570



Forearm support



- High quality PU leather or lycra covering with soft touching feelings;
- Soft and sturdy support to give optimal comfort relief for the arms;
- The inner material is soft sponge and woodboard with strong steel base for sturdiness;
- Easily attachable to all typical desktops by strong metallic fasteners and clamps;
- Stable and durable.



Leather

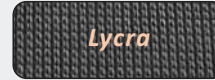

Lycra



Model No.	Forearm support board	Clamps	Technical Details	
410392-2 (Leather)			Covering:	Soft black PU leather or lycra fabric
410392-1 (Lycra)			Inner:	T15mm sponge cushion + T8mm MDF board
			Backing:	T2.2mm black powder coated steel board
			Size:	690(Length) x 215(Width) x 25(Thickness) mm
			Clamps:	3 positioning options for different table
410398-2 (Leather)			Covering:	Soft black PU leather or lycra fabric
410398-1 (Lycra)			Inner:	T15mm sponge cushion + T8mm MDF board
			Backing:	T2.2mm black powder coated steel board
			Size:	670(Length) x 225(Width) x 25(Thickness) mm
			Clamps:	3 positioning options for different table
410399-2 (Leather)			Covering:	Soft black PU leather or lycra fabric
410399-1 (Lycra)			Inner:	T6mm sponge cushion + T5mm wood board
			Backing:	T1.8mm black powder coated steel board
			Size:	685(Length) x 215(Width) x 13(Thickness) mm
			Clamps:	3 positioning options for different table
410400-2 (Leather)			Covering:	Soft black PU leather or lycra fabric
410400-1 (Lycra)			Inner:	T15mm sponge cushion + T8mm MDF board
			Backing:	T2.2mm black powder coated steel board
			Size:	685(Length) x 215(Width) x 25(Thickness) mm
			Clamps:	3 positioning options for different table
410402-2 (Leather)			Covering:	Soft black PU leather or lycra fabric
410402-1 (Lycra)			Inner:	T15mm sponge cushion + T8mm MDF board
			Backing:	T2.2mm black powder coated steel board
			Size:	670(Length) x 225(Width) x 25(Thickness) mm
			Clamps:	Foldable clamps
410404-2 (Leather)			Covering:	Soft black PU leather or lycra fabric
410404-1 (Lycra)			Inner:	T15mm sponge cushion + T8mm MDF board
			Backing:	T2.2mm black powder coated steel board
			Size:	310(Length) x 198(Width) x 25(Thickness) mm
			Clamps:	Angle adjustable freely. Positioning adjustable.
410405-2 (Leather)			Covering:	Soft black PU leather or lycra fabric
410405-1 (Lycra)			Inner:	T15mm sponge cushion + T8mm MDF board
			Backing:	T2.2mm black powder coated steel board
			Size:	700(Length) x 293(Width) x 25(Thickness) mm
			Clamps:	4 positioning options for different table

Forearm support



- › High quality linen fabric covering with soft touching feelings;
- › Soft and sturdy support to give optimal comfort relief for the arms;
- › Easy to use- no need to assemble;
- › The clamps makes the Forearm support a perfect fit for any desk no matter thickness, frames, corners or rounded shapes.
- › Stable and durable.

Model No.	Forearm support board	Clamps	Technical Details
410394			Covering: Dark grey linen fabric Inner: T8mm sponge + T15mm plywood Backing: Dark grey linen fabric (same as covering) Size: 605(Length) x 280(Width) x 23(Thickness) mm Clamps: 2 positioning options for different table
410395			Covering: Dark grey linen fabric Inner: T8mm sponge + T15mm plywood Backing: Dark grey linen fabric (same as covering) Size: 775(Length) x 280(Width) x 23(Thickness) mm Clamps: 2 positioning options for different table
410396			Covering: Dark grey linen fabric Inner: T8mm sponge + T15mm plywood Backing: Dark grey linen fabric (same as covering) Size: 605(Length) x 280(Width) x 23(Thickness) mm Clamps: 2 positioning options for different table
410397			Covering: Dark grey linen fabric Inner: T8mm sponge + T15mm plywood Backing: Dark grey linen fabric (same as covering) Size: 210(Length) x 290(Width) x 23(Thickness) mm Clamps:
410401		 <i>No clamps</i>	Covering: Soft black lycra fabric for the padding Inner: T15mm sponge cushion + T7mm plywood Backing: T1.2mm black powder coated big steel board Size: 700(Length) x 275(Width) x 24(Thickness) mm Mouse pad: ABS sheet
410403	 <i>Foldable</i>		Woodboard: T12mm MDF board Size: 310(Length) x 198(Width) x 25(Thickness) mm Clamps: Foldable Colors: Black, white, walnut, beech, Oak, Grey wood





Model No.	Forearm support board	Clamps	Technical Details
410408	 <p>Flush with the tabletop</p>		Covering: Black lycra or Dark grey linen fabric
			Inner: T8mm sponge + T15mm plywood
			Backing: Same as covering
			Size: 605(Length) x 220(Width) x 23(Thickness) mm
410409	  <p>Foldable</p>		Covering: Black lycra or
			Inner: T15mm sponge + T5mm plywood
			Backing: Same as covering
			Size: 240(Length) x 240(Width) x 23(Thickness) mm
			Clamps: Foldable

410410 TWIN Pro Heavy Duty Forearm Support



- Premium high density foam provide ultimate comfortable and supportive to the arms.
- High quality Lycra covering provide soft and smooth touching feelings.
- Heavy-Duty Steel Construction for Durability Built from premium steel, ensuring long-lasting performance.
- Sturdy metal clamps that hold everything tightly in place.
- Easy installation - NO screws or tools needed.
- Rubber pads attach to the workstation without causing any damage to your desk.
- Adjustable plastic leveling cap provide maximum stability for the board.

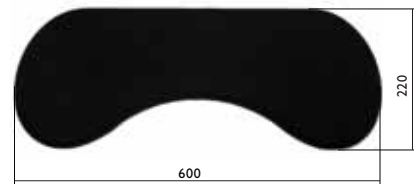

410412 TWIN Moving and Foldable Forearm Support



- Fully Adjustable:
Find the posture that's comfortable for you with an arm support offering free moving and 360° rotation.
- Solid Construction:
The durable steel material of the arm guarantees this comfortable resting place will last.
The dependable clamp mounts onto the edge of your desk securely to eliminate the risk of slipping.
- Durable leather covering with comfortable foam inside.

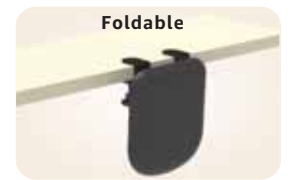
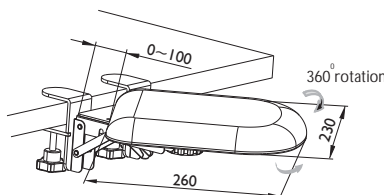

Forearm support

410413 TWIN Moving and Foldable Forearm Support



- **Movable:** Travel: 100mm. Find the posture that's comfortable for you;
- **Foldable:** 90° folded for storage when not needed
- **Solid Construction:**
The durable steel material of the arm guarantees this comfortable resting place will last. The dependable clamp mounts onto the edge of your desk securely to eliminate the risk of slipping.
- **Durable leather covering with comfortable foam inside.**

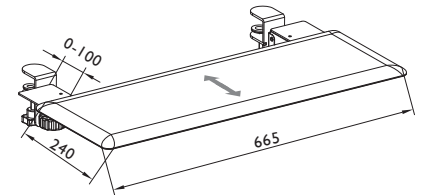
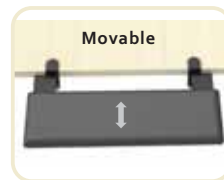
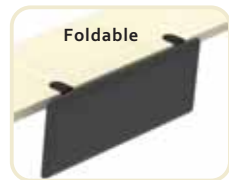

410420 TWIN Flexible Arm Rest



- **Arm Rest Solutions:**
This product adds an additional platform for arm and elbow support and is designed for both right and left-handed users
- **Fully Adjustable:**
Find the posture that's comfortable for you with an armrest offering 90° swivel and 360° rotation. Also, enjoy 2.5" of smooth and simple height adjustment along the extended and multi-jointed arm
- **Solid Construction:**
The durable steel material of the arm guarantees this comfortable resting place will last. The dependable clamp mounts onto the edge of your desk securely to eliminate the risk of slipping
- **Space-Saving Design:**
With a simple swivel, the armrest can be folded out of the way, creating an unobtrusive and space-efficient area for your workstation.

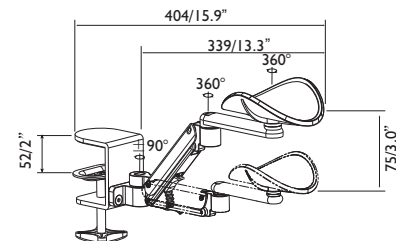

TWIN Ergonomic Heating Forearm Support



410410T



410394T



410390T



410398T



410412T

- **Stable Heat:** The heating forearm support uses a wired design with 12V power to deliver consistent, reliable warmth;
- **Fast Heating:** The heating forearm support features quick-heating technology to minimize your wait time. It offers 3 temperature settings, allowing you to customize warmth to your preference;
- **Make you feel comfortable:** This elbow heating pad can relieve pain discomfort and provide ample heat to your elbows. It provides a comfortable warming experience and keeps you warm at all times;
- **Stable and Comfortable Material:** Ergonomically designed, this heating forearm support fits well in the elbow during use and is made of soft, comfortable and durable materials to provide strong support and comfort.
- **Auto-off feature:** Your heating pad includes auto-off feature. 60-120 min auto shut-off function allowing you to enjoy warmth without worrying about accidentally leaving it on.
- **Cable included:** Universal USB and type C Cable included;
- **CE certified.**



USB Type C



100% power



70% power



50% power

57100 TWIN Single Monitor Arm Mount Stand

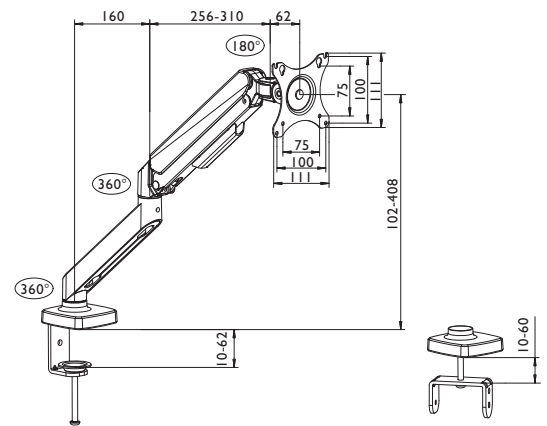

- Adjustable Gas Spring Arm Monitor Mount.
- Compatibility: computer screens size range 13~30 Inch.
- Weight Capacity: 2~9KG.
- VESA Compatible: 75X75 / 100X100.
- Tilt Range: -45~90°.
- Swivel Range: -90~90°.
- Screen Rotation: 360°.
- Colors: black, silver and white available.

57200 TWIN Dual Monitor Arm Mount Stand

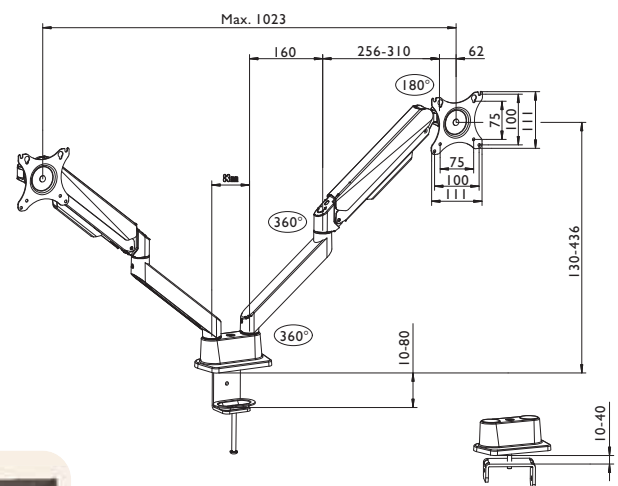

- Adjustable Gas Spring Arm Monitor Mount.
- Compatibility: computer screens size range 13~30 Inch.
- Weight Capacity: 2~9KG.
- VESA Compatible: 75X75 / 100X100.
- Tilt Range: -45~90°.
- Swivel Range: -90~90°.
- Screen Rotation: 360°.
- Colors: black, silver and white available.



TWINCO Solution ApS
Søndergade 3c
DK-4130 Viby Sjælland
Telefon: +45 7877 3587
info@twincosolution.dk
www.twinco.dk

